

M I N I A T U R E L I N E A R G U I D E S

1st Edition



[www.helixlinear.com](http://www.helixlinear.com)



# MINIATURE LINEAR GUIDES



HELIX Miniature Rails are used in many instrument series applications.

Helix Linear Technologies™, a subsidiary of Nook Industries, is the most high-tech lead screw manufacturing facility in the world. With the release of our new precision lead screws, Helix produces the broadest product line of any lead screw manufacturer globally. We offer precision rolled, milled, or ground screws in diameters from 1/8" = to 6", or 3mm to 150mm, and leads from 0.024" to 3", or 3mm to 75mm.

Helix offers a complete line of nuts in standard and anti-backlash designs with centralizing threads to match our precision lead screws. Our lead screw assemblies have the lowest backlash on the market.

## HISTORY

Nook Industries, Inc. was founded in 1969 by Joseph H. Nook, Jr. and in the decades to follow, the company has grown to become one of the leading manufacturers of linear motion products in the world.

Helix Linear Technologies, a subsidiary of Nook Industries, is one of the world's leading manufacturers of lead screws, linear actuators and motion control systems, providing precision engineered solutions.

Helix Linear Technologies' engineering expertise and broad range of core technologies uniquely positions the company to solve some of the world's greatest linear motion challenges. Helix improves customers' productivity and profitability by finding new ways to solve their biggest challenges.

With the release of our new NAB and AAB product lines, Helix has even more economical options in the 1/8" to 1" diameter range. We have also developed additional custom anti-backlash nut designs, which are available upon request.

Helix services the expanding and evolving customer-driven market for precision linear motion products. When you need Acme, Trapezoidal, or Speedy® (high lead) lead screws with a precision, low backlash nuts, or a state-of-the-art anti-backlash design, we deliver the highest quality and exceptional value to our customers.

## MISSION

Helix is committed to customer success and innovation by providing high-quality, high-value products and services that are delivered on time, at a competitive price.

Pairing traditional and proven design with the latest technology, Helix Linear Technologies manufactures products that customers value. The expansion of our product lines and the development of engineered systems have propelled Helix to the forefront of the industry.

# LINEAR GUIDANCE

## MINIATURE GUIDES



### HMR MINIATURE LINEAR GUIDE SERIES

Product Introduction ..... 2-3  
 New Design ..... 4

### TECHNICAL INFORMATION

Accuracy ..... 5  
 Preload ..... 5  
 Load Capacity and Rating Life ..... 6  
 Friction ..... 7  
 Lubrication ..... 8

















### INSTALLATION ILLUSTRATION ..... 10-11

### ORDERING INFORMATION ..... 12-13

### DIMENSIONS AND SPECIFICATIONS

Standard HMR - M SU series ..... 14-15  
 Standard HMR - M ZU series ..... 16-17  
 Standard HMR - M SS series ..... 18-19  
 Standard HMR - M ZZ series ..... 20-21  
 Standard HMR - M SUE series ..... 22-23  
 Standard HMR - M ZUE series ..... 22-23  
 Standard HMR - M EE series ..... 24-25  
 Standard HMR - M EZ series ..... 24-25  
 Standard HMR - M EU series ..... 26-27  
 Standard HMR - M UZ series ..... 26-27  
 Wide HMR - M SU series ..... 28-29  
 Wide HMR - M ZU series ..... 30-31  
 Wide HMR - W SS series ..... 32-33  
 Wide HMR - W ZZ series ..... 34-35  
 Wide HMR - M SUE series ..... 36-37  
 Wide HMR - M ZUE series ..... 36-37  
 Wide HMR - W EE series ..... 38-39  
 Wide HMR - W EZ series ..... 38-39  
 Wide HMR - M EU series ..... 40-41  
 Wide HMR - M UZ series ..... 40-41

### MARKET SEGMENTS SERVED

- |  |   |
|--|---|
|  Medical & Diagnostic |  Electronics               |
|  Aerospace            |  Transportation            |
|  Packaging            |  Tire Manufacture          |
|  Automotive           |  Entertainment             |
|  Semiconductor        |  Steel                     |
|  Military and Defense |  Chemical                  |
|  Factory Automation   |  Mobility/Patient Handling |
|  Pulp & Paper         |  Material Handling         |

### PARTNERS



## PRODUCT INTRODUCTION

### Precision

HMR Miniature linear guide series have three accuracy grades for design selection: Precision (P), High (H), Normal (N).

### Material

Regardless of series, HMR miniature linear guides use stainless steel processed material.

### Embedded inverse return design



**Designed for high load, high movement application**

**Unique ball re-circulation design**

**Steel reinforcement plate ensures sturdy assembly and longer life**



**Built-in bottom seal**

Protects runner block from outside contaminants, facilitating dust-proof operation.

**Lubrication storage design**

Environmentally-friendly system requires less lubricant.

**Material**

Regardless of series, MR miniature linear guides use stainless steel processed material.

## PRODUCT INTRODUCTION NEW DESIGN

### EMBEDDED INVERSE HOOK DESIGN FOR REINFORCED MECHANICAL INTEGRATION

When the runner block is in motion and changing direction, the circulating stainless steel balls inside the raceway generate impact force against the plastic end cap. As the demand for rapid motion in the automation industry has increased, Helix has invented a new design to improve high speed running capability. Plastic inverse hooks for miniature linear blocks tightly secure block components to handle the impact force effectively by distributing the applied stress over a large area.

### UNIQUE BALL RE-CIRCULATION DESIGN

The stainless steel ball re-circulation hole and channel constructs are fully sealed by plastic frame and end caps. The simple structure substantially reduces contact surface between steel ball and metal, thus reduces noise significantly. The lubrication oil storage embedded in the circulation channel significantly extends the re-lubricating interval, extends life and reduces preventative maintenance.

Suitable for:

- High speed belt driven mechanism
- High speed carrier design
- Automation linkage between stations.

### HMR-EE SERIES STAINLESS STEEL REINFORCED PLATES ENSURE HIGH ROBUSTNESS

Runner blocks are equipped with two stainless steel plates which reinforce the end-cap from end to end. This sturdier design supports higher running speeds. The plates can also function as scrapers to facilitate smooth travel.

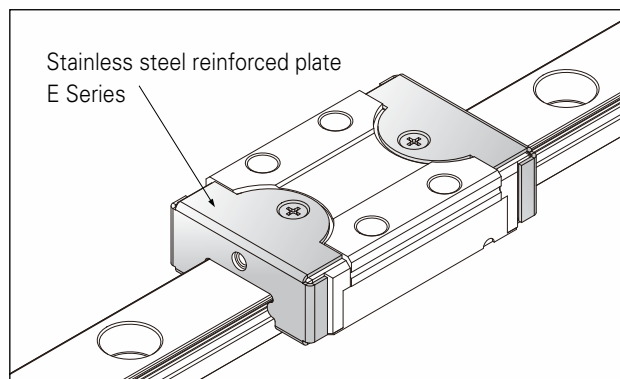

### LUBRICATION STORAGE DESIGN

Lubricant injection holes are featured at both ends of the runner block. As the balls circulate during movement of the block, the stainless steel balls carry lubrication oil to the raceway, thus efficiently lubricating the balls and the oil raceway, and achieving long-term, maintenance-free linear motion. This design also provides superb lubricating ability for short stroke movement. A newly-invented embedded lubrication pad design provides a selection of options for machine design.

(3M /W, 5M /W, 7M /W, 9M /W, 12M /W, 15M /W)

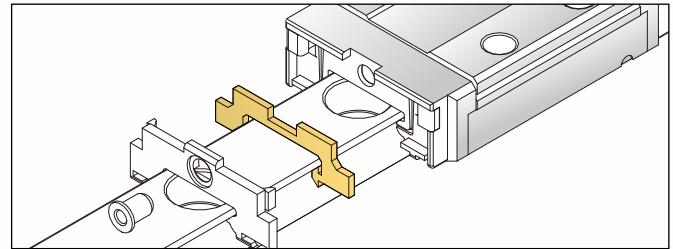

### HIGH LOAD AND HIGH MOMENT CAPACITY

The HMR Miniature Linear Guide series is designed using two rows of recirculating balls. The design uses a Gothic profile with a 45° contact angle to achieve equal load capacity in all directions. Within the restriction of limited space, larger stainless steel balls are used to enhance the load and torsion resistance capacity.

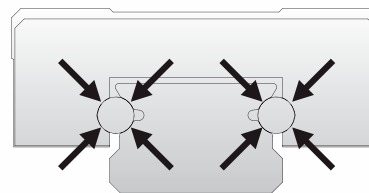

Helix linear guides (indicated with the thick black line to the right) provide greater surface contact as compared to competing products (indicated with the thin green-dotted line at right) when comparing same widths rails.

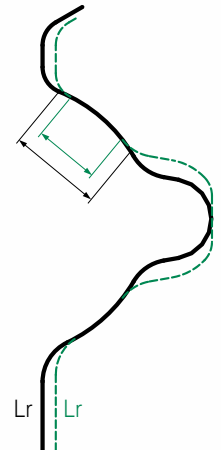

### DUST PROOF DESIGN

Our standard design comes equipped with an end seal that effectively restricts dust contamination and prolongs lubrication, ensuring longer product life. Specially-designed low friction seal lips do not affect running smoothness.



**TECHNICAL INFORMATION**

**ACCURACY**

HMR Miniature Linear Guide series have three accuracy classes: P, H, and N.

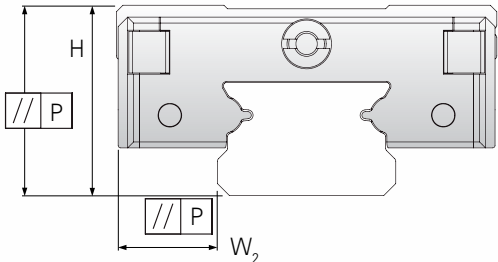

**TABLE OF ACCURACY**

Accuracy classes (µm)		Precision P	High H	Normal N*
Tolerance of dimension height H	H	±10	±20	±40
Variation of height for different runner block on the same position of rail	ΔH	7	15	25
Tolerance of dimension width W	W <sub>2</sub>	±15	±25	±40
Variation of width for different runner block on same position of rail	ΔW <sub>2</sub>	10	20	30

\* Stocked

**SPEED**

The maximum speed for the standard HMR-SS/ZZ type is:  
**Velocity<sub>max</sub> = 3 m/s**

Maximum acceleration:  
**Acceleration<sub>max</sub> = 250 m/s<sup>2</sup>**  
(if the preload V0, capable of reaching 40 m/s<sup>2</sup>)

The maximum speed for the standard HMR-EE/EZ type is:  
**Velocity<sub>max</sub> = 5 m/s**

Maximum acceleration:  
**Acceleration<sub>max</sub> = 300 m/s<sup>2</sup>**  
(if the preload V0, capable of reaching 60 m/s<sup>2</sup>)

Accuracy of the running parallelism

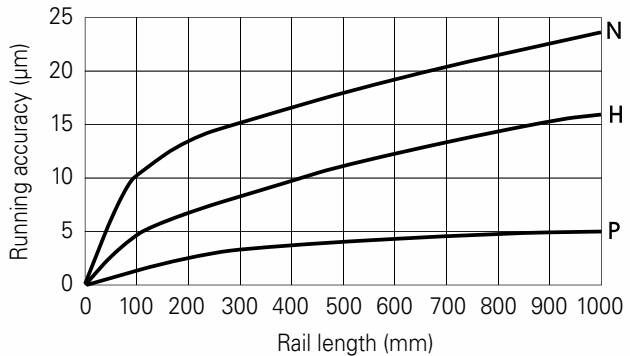

**PRELOAD CLASSES**

The HMR Miniature Linear Guide series have three degrees of preload: V0, Vs and V1 (as described in the Table of Preload below). Preload can enhance stiffness, precision, and torsion resistance, but will negatively affect life and friction.

**TABLE OF PRELOAD**

Preload type	Model code	Clearance (µm)						Application
		3	5	7	9	12	15	
<b>Clearance*</b>	<b>V0</b>	3 - 0	3 - 0	4 - 0	4 - 0	5 - 0	6 - 0	Very smooth
<b>Standard</b>	<b>Vs</b>	1 - 0	1 - 0	2 - 0	2 - 0	2 - 0	3 - 0	Smooth and precision
<b>Light preload</b>	<b>V1</b>	0 - -0.5	0 - -1	0 - -3	0 - -4	0 - -5	0 - -6	High rigidity Minimize vibration High precision Load balance

\* Stocked

The specifications and data in this publication are believed to be accurate and reliable. However, it is the responsibility of the product user to determine the suitability of Helix Linear Technologies products for a specific application. While defective products will be replaced without charge if promptly returned, no liability is assumed beyond such replacement.

## TECHNICAL INFORMATION

### LIFE

#### Static Load Rating C

For the static load traveling along the acting direction, the maximum calculated stress at the rolling elements and the raceway, by a curvature radius  $\leq 0.52$ , is 4200MPa and, by a curvature radius  $\geq 0.6$ , is 4600MPa.

To convert 100kl of life to 50kl of live, use the following formula:

$$C_{50} = 1.26 \times C_{100}$$

**Note:** Under such stress, a permanent total deformation is generated at this contact point corresponding to about 0.0001 times the rolling element diameter (ISO 14728-2).

#### Static Moment Ratings M

For C, C<sub>0</sub>, M of each model refer to dimensional table. Helix Precision Profile Rails have the same dynamic load capacity in four directions: radial, reverse-radial and bi-lateral.

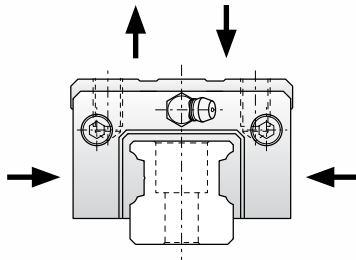

#### Static Safety Factor

Generally, the maximum permitted static load on the runner block is equivalent to static load ratings C<sub>0</sub>. However, in repeated linear motion applications, unexpected load is caused by the inertia when the system starts or stops. Therefore, the safety factor f<sub>s</sub> should be calculated in order to determine the allowable load.

Where:

$$\frac{C_0}{P_0} \geq f_s$$

C<sub>0</sub> = static load ratings  
P<sub>0</sub> = equivalent load (static load, impact load)  
f<sub>s</sub> = static safety factor

The value of f<sub>s</sub> for general use is indicated in the table below:

OPERATING CONDITION	Minimum f <sub>s</sub>
Normal operation	1~3
Smooth running required	3~4
Operation with impact or vibration	4~5

#### Dynamic Load Rating C

When the dynamic loads are applied to normal load zones with constant magnitude and direction, theoretically, the rate life of a linear guide can reach 100 km of travel distance (ISO 14728-1).

#### Rating Life L

The dynamic rating is based on 100km of life. When the standard of 50km travel distance is used, the dynamic load rating will exceed the value based on the standard ISO 14728-1 by 20% or more.

$$L = 100 \times \left(\frac{C}{P}\right)^3$$

Where:

L = expected life  
C = basic load ratings  
P = equivalent load

Where the stroke (m) and the number of cycles per minute n<sub>1</sub> (cpm) are constant, the rated fatigue life L<sub>n</sub> (hr) is calculated by the following formula.

$$L_n = \frac{100 \times 10^3}{120 \times l_s \times n_1} \times \left(\frac{C}{P}\right)^3$$

Where:

L<sub>n</sub> = expected Life (hr)  
l<sub>s</sub> = stroke length (m)  
n<sub>1</sub> = number of strokes per minute

#### EQUIVALENT DYNAMIC LOAD AND SPEED

If the load and speed are not constant, each actual load and speed must be taken into account and both will influence the life.

#### Equivalent Dynamic Load

If there is a change in load only, the equivalent dynamic load can be calculated according to the following formula:

$$P = 3 \sqrt{\frac{q_1 \times F_1^3 + q_2 \times F_2^3 + \dots + q_n \times F_n^3}{100}}$$

Where:

P = Equivalent dynamic load (N)  
q<sub>n</sub> = Percentage of stroke (%)  
F<sub>n</sub> = Discrete load steps (N)

#### Combined Dynamic Load

If the linear guide takes on load from an arbitrary angle, it's equivalent dynamic load rating is calculated using the following formula:

$$P = F_x + F_y$$

Where:

P = Equivalent dynamic load (N)  
F<sub>y</sub> = External dynamic load, vertical N  
F<sub>x</sub> = External dynamic load, horizontal N



### Equivalent Speed

If there is a change in speed only, the equivalent speed can be calculated using the following formula:

$$v = \frac{q_1 \times v_1 + q_2 \times v_2 + \dots + q_n \times v_n}{100}$$

Where:

- P = Equivalent dynamic load (N)
- q<sub>n</sub> = Percentage of stroke (%)
- v = Average speed (m/min)
- v<sub>n</sub> = Discrete speed steps (m/min)

If there are changes in both load and speed, the equivalent dynamic load can be calculated using the following formula:

$$P = \sqrt[3]{\frac{q_1 \times v_1 \times F_1^3 + q_2 \times v_2 \times F_2^3 + \dots + q_n \times v_n \times F_n^3}{100}}$$

### Combining Linear Forces with Moment Loads

If both load and moment act on the linear guide, the equivalent dynamic load can be calculated by the formula.

$$P = F + M \times \frac{C_0}{M_0}$$

Where:

- P = Equivalent dynamic load (N)
- F<sub>n</sub> = External dynamic load N
- M = Static moment Nm
- M<sub>0</sub> = Static moment rating Nm

According to ISO 14728-1, the equivalent load(P) shall not exceed ½C.

### FRICITION

The HMR miniature linear guide series is characterized with light starting friction and low, stable and consistent friction during operation.

$$F_m = \mu \times F$$

Where:

- F = Load (N)
- F<sub>m</sub> = Friction (N)

HMR Miniature linear Guide series friction factor is approximately μ=0.002-0.003.

### Source of friction

- Resistance of the sealing system
- Resistance of the collision between the balls during operation
- Resistance from the collision between the balls and the return path
- Rolling resistance of the balls in the gothic arch load zone
- Resistance from the churning of the lubricant in the runner block
- Resistance from the penetrated contaminant

### FRICITION WITH END SEAL UNDER LUBRICATION

HMR size	Friction with End Seal (N <sub>max</sub> ) (under lubrication)	
	M	W
2	0.08	0.2
3	0.08	0.2
5	0.08	0.2
7	0.1	0.4
9	0.1	0.8
12	0.4	1.0
15	1.0	1.0

### SEALING DESIGN

The HMR miniature linear guide series adopts end seals on both ends of the runner block. Optional side seals build an all-around closed sealing system.

### OPERATING TEMPERATURE

The HMR miniature linear guide can operate in a range of temperatures from -40°C - 80°C. For short term operation it can reach up to 100°C.

## TECHNICAL INFORMATION

### LUBRICATION

The loaded rolling elements and the raceway will be separated at the contact zone by a thin layer of oil.

The effective lubrication will:

- Reduce friction
- Reduce wear
- Prevent corrosion
- Dissipate heat and increase service life

#### Oil Lubrication

Helix recommends LBL1 (see page 198). A lubricant formulated for rolling friction should be used with Helix Linear Bearings. In applications where operating speeds are low and loads are light, Helix linear bearings can be used without lubrication at a reduced life. However, to protect the highly polished bearing surfaces from corrosion and wear, a lubricant is recommended.

### LUBRICATION INTERVAL

Speed, load, stroke length, and operating environment affect re-lubrication interval. A safe lubrication interval can only be obtained by practical observation.

Lubrication interval shall not exceed one year. Lubrication can be applied through the injection hole on both ends of the block by using a special injector available from Helix.

- Lubrication shall be applied before lubricant is contaminated or changes color
- Amount of lubricant is 1/2 of the first lubrication. If lubricant oil is applied, add until oil over flows (see Table 1 below)
- Lubrication shall be applied under operation temperature. Move block back and forth while adding lubricant to ensure even distribution. **Water based lubricant oil should not be applied to the block or rail.**
- If the stroke is smaller than one time or greater than 10 times the block steel body length, the re-lubrication interval shall be shortened

TABLE 1

Model code	First lube (cm <sup>3</sup> )	Model Code	First lube(cm <sup>3</sup> )
3MN	0.02	2WL/3WN	0.03
3ML	0.03	3WL	0.04
5MN	0.03	5WN	0.04
5ML	0.04	5WL	0.05
7MN	0.12	7WN	0.19
7ML	0.16	7WL	0.23
9MN	0.23	9WN	0.30
9ML	0.30	9WL	0.38
12MN	0.41	12WN	0.52
12ML	0.51	12WL	0.66
15MN	0.78	15WN	0.87
15ML	1.05	15WL	1.11

### Caution

- For the ZZ and EZ series:
  1. Block contains lubricant which can be directly installed on the machine with no need to be washed.
  2. If washing the blocks, please do not soak the block in the lubricant before both the detergent of lubrication storage area and Cleaning Naphtha are totally dry. The block is ready for installation only on the condition that the lubrication storage area is full of the lubricant.
- The linear guide must be lubricated for protection before the first use. Contamination of any kind should be avoided
- The runner block should be moved back and forth during lubrication
- Generally, the lubricant can be added onto rail raceway
- The lubricant can be injected into the lubrication holes on either end of the runner block
- A thin coating of lubricant should be maintained on the surface of the rail raceway at all times
- Re-lubricate before contamination or discoloration of the lubricant occurs
- Notify Helix Engineering when used in acidic, alkaline or clean room applications
- Contact Helix Engineering for lubrication assistance if the runner block is used in a wall mount configuration

### LUBRICATION APPLICATOR

When reordering lubrication applicator, please specify appropriate part number and needle:

LUB – LBL1 – XXX  
 XXX=Needle model  
 Part No.

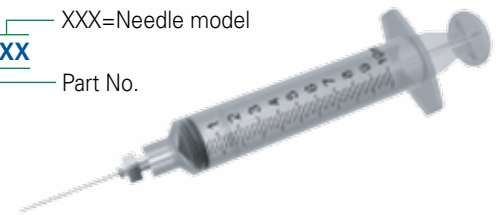

MODEL CODE	NEEDLE
5M/5W	21G
7M	20G
7W	19G
9M/9W	18G
12M/12W	18G
15M/15W	15G

**Note:** Applicator does not come prefilled. Capacity = 10ml. LBL1 is the recommended lubricant. Other lubricants are available.

### Grease Lubrication

When lubricant grease is required, synthetic oil-based lithium soap grease with a viscosity between ISO VG32-100 is recommended.

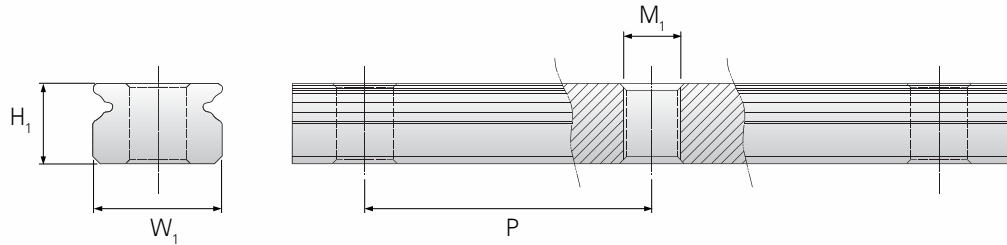

### UPWARD MOUNTING STANDARD HMRU-M SERIES

RAIL DIMENSIONS (mm)

Model	H <sub>1</sub>	W <sub>1</sub>	P	M <sub>1</sub>
HMRU 3M	2.6	3	10	M1.6 × 0.35
HMRU 5M	3.5	5	15	M3 × 0.5
HMRU 7M	4.7	7	15	M3 × 0.5
HMRU 9M	5.5	9	20	M4 × 0.7
HMRU 12M	7.5	12	25	M4 × 0.7
HMRU 15M	9.5	15	40	M4 × 0.7

### UPWARD MOUNTING WIDE HMRU-W SERIES

RAIL DIMENSIONS (mm)

Model	H <sub>1</sub>	W <sub>1</sub>	P	M <sub>1</sub>
HMRU 3W	2.7	6	15	M3 × 0.5
HMRU 5W	4	10	20	M3 × 0.5
HMRU 7W	5.2	14	30	M4 × 0.7
HMRU 9W	7.5	18	30	M4 × 0.7
HMRU 12W	8.5	24	40	M5 × 0.8
HMRU 15W	9.5	42	40	M5 × 0.8

## INSTALLATION ILLUSTRATION

### REFERENCE SURFACE HEIGHT AND CHAMFERED

To avoid any interference, the corner of the reference edge should have a chamfer. If not, please refer to the following table for the height of the reference edge corner and the height of the reference edge.

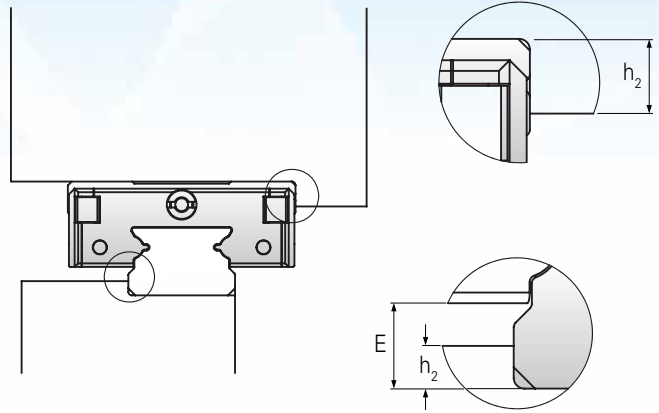

### HEIGHT AND CHAMFERED THE REFERENCE SURFACE

DIMENSIONS	$h_1$	$r_{1,max}$	$h_2$	$r_{2,max}$	E
3M SS	0.5	0.2	1.5	0.3	1
3M SU/ZU	0.5	0.2	1.5	0.3	0.9
5M SS	1.2	0.2	1.9	0.3	1.5
5M SU/ZU	1	0.2	1.9	0.3	1.4
5M EE/EZ	0.6	0.2	1.9	0.3	1.1
5M SUE/ZUE	0.5	0.2	1.9	0.3	1
7M SS/ZZ	1.2	0.3	2.8	0.3	1.5
7M SU/ZU	0.8	0.3	2.8	0.3	1.3
9M SS/ZZ	1.5	0.3	3	0.3	2.2
9M SU/ZU	1.5	0.3	3	0.3	2
9M EE/EZ	1.2	0.3	3	0.3	1.7
9M EU/UZ	1	0.3	3	0.3	1.4
9M SUE/ZUE	1	0.3	3	0.3	1.5
12M SS/ZZ	2.5	0.5	4	0.5	3
12M SU/ZU	2.3	0.5	4	0.5	2.8
12M EE/EZ	1.5	0.5	4	0.5	2.3
12M EU/ZU	1.5	0.5	4	0.5	2
12M SUE/ZUE	1.5	0.5	4	0.5	2.1
15M SS/ZZ	2.5	0.5	4.5	0.5	4
15M SU/ZU	2.5	0.5	4.5	0.5	3.7
15M EE/EZ	2.5	0.5	4.5	0.5	3.2
15M EU/UZ	2	0.5	4.5	0.5	2.9
15M SUE/ZUE	2.4	0.5	4.5	0.5	2.9

DIMENSIONS	$h_1$	$r_{1,max}$	$h_2$	$r_{2,max}$	E
2WL SS/ZZ	0.5	0.2	1.7	0.3	1
2WL SU/ZU	0.5	0.2	1.7	0.3	0.9
2W EE/EZ	0.6	0.2	1.5	0.3	0.7
2W SUE/ZUE	0.4	0.2	1.5	0.3	0.6
3W SS	0.7	0.2	1.7	0.3	1
3W SU/ZU	0.6	0.2	1.7	0.3	0.9
5W SS	1.2	0.2	2	0.3	1.5
5W SU/ZU	0.9	0.2	2	0.3	1.4
7W SS/ZZ	1.2	0.3	2.8	0.3	2
7W SU/ZU	1.3	0.3	2.8	0.3	1.8
7W EE/EZ	1	0.3	2.8	0.3	1.5
7W SUE/ZUE	0.9	0.3	2.8	0.3	1.4
9W SS/ZZ	1.5	0.3	3	0.3	4.2
9W SU/ZU	2.5	0.3	3	0.3	3.2
9W EE/EZ	2	0.3	3	0.3	2.8
9W EU/UZ	1.5	0.3	3	0.3	2.5
9W SUE/ZUE	2	0.3	3	0.3	2.6
12W SS/ZZ	2.5	0.5	4	0.5	3.9
12W SU/ZU	2.5	0.5	4	0.5	3.6
12W EE/EZ	2.5	0.5	4	0.5	3.3
15W SS/ZZ	2.5	0.5	4.5	0.5	4
15W SU/ZU	2.5	0.5	4.5	0.5	3.7
15W EE/EZ	2.5	0.5	4.5	0.5	3.2
15W EU/UZ	2	0.5	4.5	0.5	2.9
15W SUE/ZUE	2	0.5	4.5	0.5	2.9

### THE MOUNTING SURFACE

Surface roughness – the mounting surface should be ground or fine milled to reach a surface roughness Ra1.6.

### SCREW TIGHTENING TORQUE (Nm)

Screw Grade 12.9	Steel	Cast Iron	Non Iron Metal
M2	0.6	0.4	0.3
M3	1.8	1.3	1
M4	4	2.5	2

### GEOMETRIC AND POSITIONAL ACCURACY OF THE MOUNTING SURFACE

Inaccurate mounting surfaces will affect the operational accuracy of the linear guide. The rating lifetime will also be shortened. Insure the mounting surface height differential is greater than the values calculated by the formulas below.

$$e_1 \text{ (mm)} = b \text{ (mm)} \times f_1 \times 10^{-4}$$

$$e_2 \text{ (mm)} = d \text{ (mm)} \times f_2 \times 10^{-5}$$

$$e_3 \text{ (mm)} = f_3 \times 10^{-3}$$

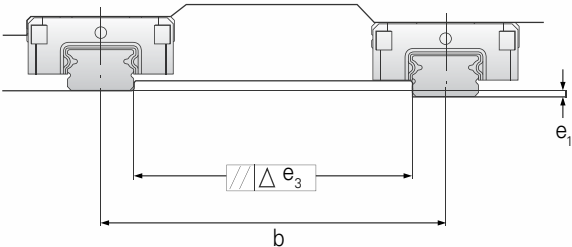

### REFERENCE SURFACE

Rail: Both sides of the track rail can be the reference surface without any special marking.

Block: Reference edge is opposite to the groove marking side.

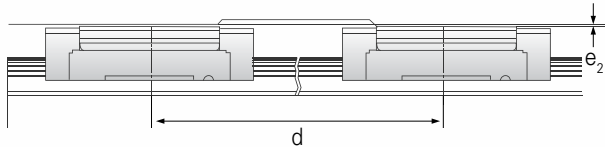

DIMENSION	Preload V0/VS			Preload V1		
	f <sub>1</sub>	f <sub>2</sub>	f <sub>3</sub>	f <sub>1</sub>	f <sub>2</sub>	f <sub>3</sub>
3MN	4	9	2	3	9	1
5MN	4	8	2	2	8	2
7MN	5	11	4	3	10	3
9MN	5	11	6	4	10	4
12MN	6	13	8	4	12	6
15MN	7	11	12	5	10	8
3ML	4	5	2	3	5	1
5ML	3	5	2	2	5	1
7ML	4	6	4	3	6	3
9ML	5	7	5	3	7	4
12ML	5	8	8	3	7	5
15ML	7	8	11	4	8	7

DIMENSION	Preload V0/VS			Preload V1		
	f <sub>1</sub>	f <sub>2</sub>	f <sub>3</sub>	f <sub>1</sub>	f <sub>2</sub>	f <sub>3</sub>
2WL	4	5	2	3	5	1
3WN	2	5	2	4	3	1
5WN	2	5	2	1	3	1
7WN	2	6	4	2	4	3
9WN	2	7	6	2	5	4
12WN	3	8	8	2	5	5
15WN	2	9	11	1	6	7
3WL	2	3	1	1	2	1
5WL	2	3	2	1	2	1
7WL	2	4	4	1	3	3
9WL	2	5	5	2	3	3
12WL	2	5	7	2	3	5
15WL	2	5	10	1	4	7

## REFERENCE NUMBER SYSTEM

**ASSEMBLY** HMR 15 M N / EE / 2 / V1 N / 310 - 15 / JC3

### PRODUCT TYPE

HMR = Miniature Linear Guide

### RAIL

**Dimension** The Width of Rail ex. = 2, 3, 5, 7, 9, 12, 15 — **15 M**  
**Type** M = Standard W = Wide

### BLOCK TYPE

L = Long, N = Standard

### SEAL TYPE

SS = End Seal  
 ZZ = End Seal, Lubrication Storage  
 SU = End Seal, Bottom Seal\*  
 ZU = End Seal, Bottom Seal, Lubrication Storage\*  
 EE = End Seal, Reinforcement Plate  
 EZ = End Seal, Lubrication Storage, Reinforcement Plate

SUE = End Seal, Reinforcement Plate, Bottom Seal  
 ZUE = End Seal, Reinforcement Plate, Bottom Seal, Lubrication Storage

\* Stocked

### QUANTITY OF RUNNER BLOCK

### CLASSES

**Preload** V0 = Clearance VS = Standard V1 = Light Preload

**Accuracy** N = Normal P = Precision H = High

### LENGTH

Length (mm) — **310 - 15**

Center of Starting Hole from Left Guide Edge (mm)

### CUSTOMIZATION CODE

See Customization Code on the following page.

## RAIL ONLY

HMR 15 M / 310 - 15

### PRODUCT TYPE

HMR = Miniature Linear Guide

### RAIL

**Dimension** The width of rail ex. = 2, 3, 5, 7, 9, 12, 15  
**Type** M = Standard W = Wide

### LENGTH

Length (mm) — **310 - 15**

Center of Starting Hole from Left Guide Edge (mm)



### RAIL LENGTH

		WIDE RAIL						
Size		2W	3W	5W	7W	9W	12W	15W
Standard Length of one rail (mm)	30	40	50	50	50	70	110	
	40	55	70	80	80	110	150	
	50	70	90	110	110	150	190	
				110	140	140	190	230
				130	170	170	230	270
				150	200	200	270	310
				170	260	260	310	430
					290	290	390	550
						320	470	670
							550	790
Pitch (mm)		10	15	20	30	30	40	40
L <sub>2</sub> , L <sub>3</sub> min		3	3	4	3	4	4	4
L <sub>2</sub> , L <sub>3</sub> max		5	10	15	25	25	35	35
L <sub>max</sub>		300	1000	1000	1000	1000	1000	1000

		STANDARD RAIL						
Size		3M	5M	7M	9M	12M	15M	
Standard Length of one rail (mm)	30	40	40	55	70	70		
	40	55	55	75	96	110		
	50	70	70	95	120	150		
			85	85	115	145	190	
			100	100	135	170	230	
					130	155	196	270
						175	220	310
						195	245	350
						275	270	390
						375	320	430
							370	470
							470	550
							570	670
							870	
Pitch (mm)		10	15	15	20	25	40	
L <sub>2</sub> , L <sub>3</sub> min		3	3	3	4	4	4	
L <sub>2</sub> , L <sub>3</sub> max		5	10	10	20	20	35	
L <sub>max</sub>		300	1000	1000	1000	1000	1000	

### LENGTH OF RAIL

Butt-jointing is required when lengths exceed L<sub>max</sub>. (For detailed information, please contact Helix technical support)

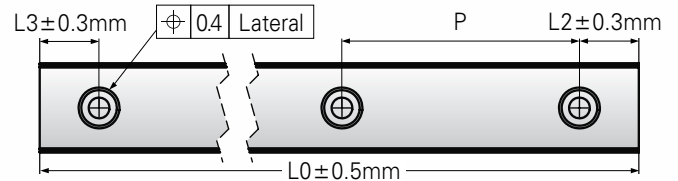

### CUSTOMIZATION CODE

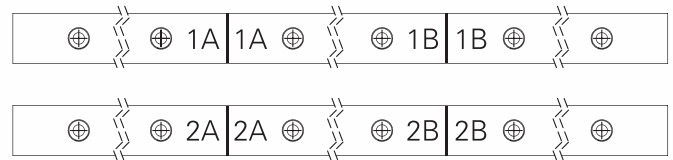

### J = Butt-jointing Track Rail

When the required length of the customer's rail exceeds the standard rail length, a butt-joint can be specified. The rail butt-joint indication is marked as illustrated above.

### B = Special Process for Block

For special process requirements, please contact Helix Engineering.

### C3 or C4 = Plugs For Mounting Holes on Rail

C3 applies to HMR9M, HMR12M, HMR15M, HMR7W & HMR9W rails. C4 applies to HMR12W, HMR15W rails. All rails are shipped with plugs for mounting holes unless otherwise specified.

### R = Special Process for Rail

For special process requirements, please contact Helix Engineering

### S = Special Straightness for Rail

The straightness of the linear guide rail is specially calibrated by precision fine grinding.

### G = Customer Designate Lubricant

According to application environment.

### GN = No Lubricant

### GC = Low Dust Generation

Suitable for clean room environments.

### I = Inspection Report

Please contact Helix Engineering.

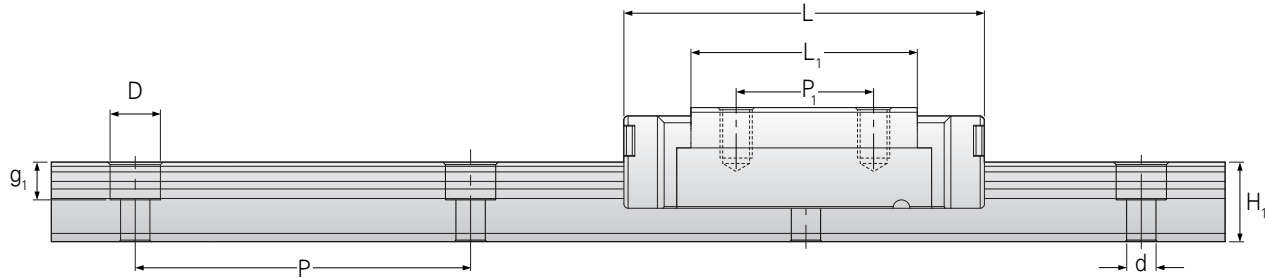

**STANDARD HMR-M** **SU - END SEAL, BOTTOM SEAL**  
**MN - STANDARD BLOCK LENGTH**  
**ML - LONG BLOCK LENGTH**  
**FOUR TAPPED HOLES**

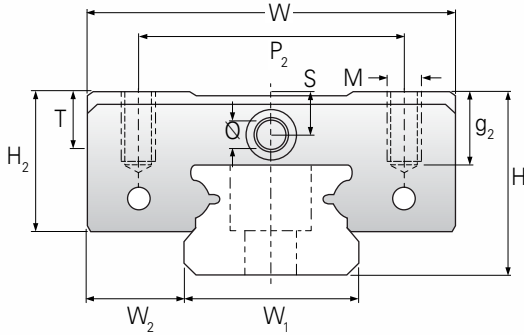

Model	FABRICATE DIMENSION		RAIL DIMENSIONS (mm)				BLOCK DIMENSIONS (mm)					
	Height	Width	W <sub>1</sub>	H <sub>1</sub>	P	D × d × g <sub>1</sub>	Width		Length			
	H	W <sub>2</sub>					W	L	L <sub>1</sub>	h <sub>2</sub>	P <sub>1</sub>	P <sub>2</sub>
HMR 3MN SU	4	2.5	3	2.6	10	M1.6	8	11.7	6.7	3.1	3.5	—
HMR 3ML SU	4	2.5	3	2.6	10	M1.6	8	16	11	3.1	5.5	—
HMR 5MN SU	6	3.5	5	3.5	15	3.5 × 2.4 × 1	12	16	10	4.6	—	8
HMR 5ML SU	6	3.5	5	3.5	15	3.5 × 2.4 × 1	12	19.6	13.5	4.6	7	—
HMR 7MN SU	8	5	7	4.7	15	4.2 × 2.4 × 2.3	17	23.7	14.3	6.7	8	12
HMR 7ML SU	8	5	7	4.7	15	4.2 × 2.4 × 2.3	17	31.2	21.8	6.7	13	12
HMR 9MN SU	10	5.5	9	5.5	20	6 × 3.5 × 3.5	20	30.6	20.5	8	10	15
HMR 9ML SU	10	5.5	9	5.5	20	6 × 3.5 × 3.5	20	40.9	30.8	8	16	15
HMR 12MN SU	13	7.5	12	7.5	25	6 × 3.5 × 4.5	27	35.4	22	10.2	15	20
HMR 12ML SU	13	7.5	12	7.5	25	6 × 3.5 × 4.5	27	47.6	34	10.2	20	20
HMR 15MN SU	16	8.5	15	9.5	40	6 × 3.5 × 4.5	32	43	27	12.3	20	25
HMR 15ML SU	16	8.5	15	9.5	40	6 × 3.5 × 4.5	32	60	44	12.3	25	25

Load capacities are calculated according to ISO 14728. To compare the rating life definition and the load capacities:  $C_{50} = 1.26 \times C_{100}$



BLOCK DIMENSIONS (mm)				BASIC LOAD RATINGS (N)		STATIC MOMENT RATINGS (Nm)			WEIGHT	
M × g <sub>2</sub>	Ø	S	T	Dynamic	Static				Block	Rail
				C <sub>100</sub>	C <sub>0</sub>	g	g/m			
M1.6 × 1.1	0.3	0.7	1.5	190	310	0.4	0.4	0.6	0.9	53
M2 × 1.1	0.3	0.7	1.5	295	575	1.1	1.1	0.9	1.2	53
M2 × 1.5	0.7	1.3	2	335	550	1	1	1.7	3.5	116
M2.6 × 2.0	0.7	1.3	2	470	900	2.1	2.1	2.4	4	116
M2 × 2.5	1.1	1.6	2.8	890	1,400	3.3	3.3	5.2	8	215
M2 × 2.5	1.1	1.6	2.8	1,310	2,440	7.7	7.7	9	14	215
M3 × 3.0	1.3	2.2	3.3	1,570	2,495	6.4	6.4	11.7	18	301
M3 × 3.0	1.3	2.2	3.3	2,135	3,880	12.4	12.4	18.2	28	301
M3 × 3.5	1.3	3.2	4.3	2,308	3,465	12.9	12.9	21.5	34	602
M3 × 3.5	1.3	3.2	4.3	3,240	5,630	30.2	30.2	34.9	51	602
M3 × 5.5	1.8	3.3	4.3	3,810	5,590	27	27	43.6	61	930
M3 × 5.5	1.8	3.3	4.3	5,350	9,080	63.3	63.3	70	90	930

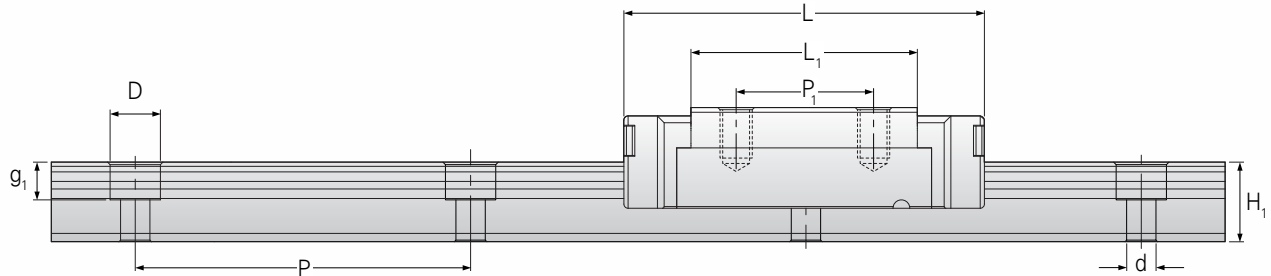

**STANDARD HMR-M** **ZU - END SEAL, BOTTOM SEAL, LUBRICATION STORAGE**  
**MN - STANDARD BLOCK LENGTH**  
**ML - LONG BLOCK LENGTH**  
**FOUR TAPPED HOLES**

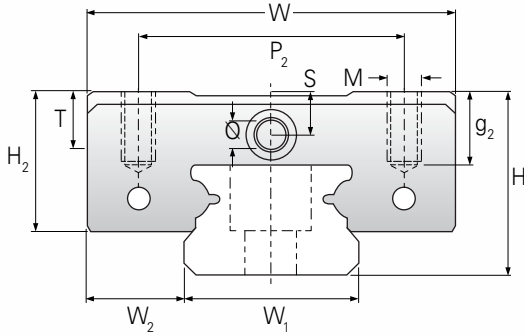

Model	FABRICATE DIMENSION		RAIL DIMENSIONS (mm)				BLOCK DIMENSIONS (mm)					
	Height	Width	W <sub>1</sub>	H <sub>1</sub>	P	D × d × g <sub>1</sub>	Width		Length			
	H	W <sub>2</sub>					W	L	L <sub>1</sub>	h <sub>2</sub>	P <sub>1</sub>	P <sub>2</sub>
HMR 3MN ZU	4	2.5	3	2.6	10	M1.6	8	11.7	6.7	3.1	3.5	—
HMR 3ML ZU	4	2.5	3	2.6	10	M1.6	8	16	11	3.1	5.5	—
HMR 5MN ZU	6	3.5	5	3.5	15	3.5 × 2.4 × 1	12	16	10	4.6	—	8
HMR 5ML ZU	6	3.5	5	3.5	15	3.5 × 2.4 × 1	12	19.6	13.5	4.6	7	—
HMR 7MN ZU	8	5	7	4.7	15	4.2 × 2.4 × 2.3	17	23.7	14.3	6.7	8	12
HMR 7ML ZU	8	5	7	4.7	15	4.2 × 2.4 × 2.3	17	31.2	21.8	6.7	13	12
HMR 9MN ZU	10	5.5	9	5.5	20	6 × 3.5 × 3.5	20	30.6	20.5	8	10	15
HMR 9ML ZU	10	5.5	9	5.5	20	6 × 3.5 × 3.5	20	40.9	30.8	8	16	15
HMR 12MN ZU	13	7.5	12	7.5	25	6 × 3.5 × 4.5	27	35.4	22	10.2	15	20
HMR 12ML ZU	13	7.5	12	7.5	25	6 × 3.5 × 4.5	27	47.6	34	10.2	20	20
HMR 15MN ZU	16	8.5	15	9.5	40	6 × 3.5 × 4.5	32	43	27	12.3	20	25
HMR 15ML ZU	16	8.5	15	9.5	40	6 × 3.5 × 4.5	32	60	44	12.3	25	25

Load capacities are calculated according to ISO 14728. To compare the rating life definition and the load capacities:  $C_{50} = 1.26 \times C_{100}$



BLOCK DIMENSIONS (mm)				BASIC LOAD RATINGS (N)		STATIC MOMENT RATINGS (Nm)			WEIGHT	
M × g <sub>2</sub>	Ø	S	T	Dynamic	Static				Block	Rail
				C <sub>100</sub>	C <sub>0</sub>	g	g/m			
M1.6 × 1.1	0.3	0.7	1.5	190	310	0.4	0.4	0.6	0.9	53
M2 × 1.1	0.3	0.7	1.5	295	575	1.1	1.1	0.9	1.2	53
M2 × 1.5	0.7	1.3	2	335	550	1	1	1.7	3.5	116
M2.6 × 2.0	0.7	1.3	2	470	900	2.1	2.1	2.4	4	116
M2 × 2.5	1.1	1.6	2.8	890	1,400	3.3	3.3	5.2	8	215
M2 × 2.5	1.1	1.6	2.8	1,310	2,440	7.7	7.7	9	14	215
M3 × 3.0	1.3	2.2	3.3	1,570	2,495	6.4	6.4	11.7	18	301
M3 × 3.0	1.3	2.2	3.3	2,135	3,880	12.4	12.4	18.2	28	301
M3 × 3.5	1.3	3.2	4.3	2,308	3,465	12.9	12.9	21.5	34	602
M3 × 3.5	1.3	3.2	4.3	3,240	5,630	30.2	30.2	34.9	51	602
M3 × 5.5	1.8	3.3	4.3	3,810	5,590	27	27	43.6	61	930
M3 × 5.5	1.8	3.3	4.3	5,350	9,080	63.3	63.3	70	90	930

**STANDARD HMR-M** **SS - END SEAL**  
**MN - STANDARD BLOCK LENGTH**  
**ML - LONG BLOCK LENGTH**  
**FOUR TAPPED HOLES**

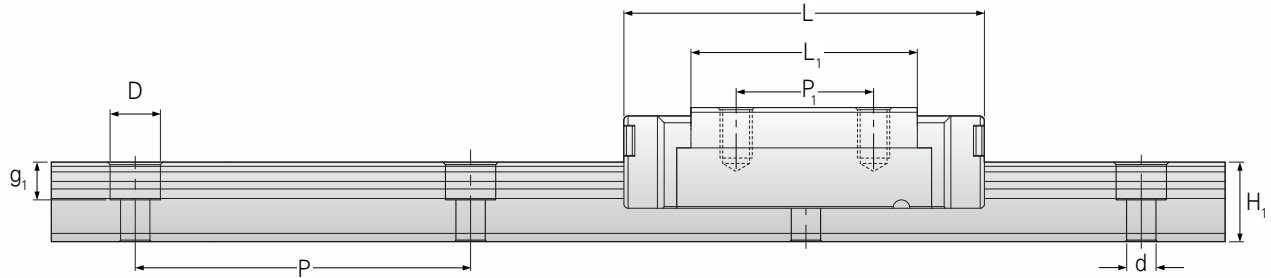



Model	FABRICATE DIMENSION		RAIL DIMENSIONS (mm)				BLOCK DIMENSIONS (mm)					
	Height	Width	W <sub>1</sub>	H <sub>1</sub>	P	D × d × g <sub>1</sub>	Width		Length			
	H	W <sub>2</sub>					W	L	L <sub>1</sub>	h <sub>2</sub>	P <sub>1</sub>	P <sub>2</sub>
HMR 3MN SS	4	2.5	3	2.6	10	M1.6	8	11.7	6.7	3.1	3.5	—
HMR 3ML SS	4	2.5	3	2.6	10	M1.6	8	16	10	3.1	5.5	—
HMR 5MN SS	6	3.5	5	3.5	15	3.5 × 2.4 × 1	12	16	11	4.6	—	8
HMR 5ML SS	6	3.5	5	3.5	15	3.5 × 2.4 × 1	12	19.6	13.5	4.5	7	—
HMR 7MN SS	8	5	7	4.7	15	4.2 × 2.4 × 2.3	17	23.7	14.3	6.5	8	12
HMR 7ML SS	8	5	7	4.7	15	4.2 × 2.4 × 2.3	17	31.2	21.8	6.5	13	12
HMR 9MN SS	10	5.5	9	5.5	20	6 × 3.5 × 3.5	20	30.6	20.5	7.8	10	15
HMR 9ML SS	10	5.5	9	5.5	20	6 × 3.5 × 3.5	20	40.9	30.8	7.8	16	15
HMR 12MN SS	13	7.5	12	7.5	25	6 × 3.5 × 4.5	27	35.4	22	10	15	20
HMR 12ML SS	13	7.5	12	7.5	25	6 × 3.5 × 4.5	27	47.6	34	10	20	20
HMR 15MN SS	16	8.5	15	9.5	40	6 × 3.5 × 4.5	32	43	27	12	20	25
HMR 15ML SS	16	8.5	15	9.5	40	6 × 3.5 × 4.5	32	60	44	12	25	25

Load capacities are calculated according to ISO 14728. To compare the rating life definition and the load capacities:  $C_{50} = 1.26 \times C_{100}$

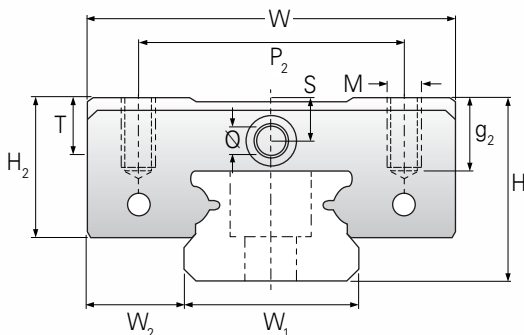



BLOCK DIMENSIONS (mm)				BASIC LOAD RATINGS (N)		STATIC MOMENT RATINGS (Nm)			WEIGHT	
M × g <sub>2</sub>	Ø	S	T	Dynamic	Static				Block	Rail
				C <sub>100</sub>	C <sub>0</sub>	g	g/m			
M1.6 × 1.1	0.3	0.7	1.5	190	310	0.4	0.4	0.6	0.9	53
M2 × 1.1	0.3	0.7	1.5	295	575	1.1	1.1	0.9	1.2	53
M2 × 1.5	0.7	1.3	2	335	550	1	1	1.7	3.5	116
M2.6 × 2.0	0.7	1.3	2	470	900	2.1	2.1	2.4	4	116
M2 × 2.5	1.1	1.6	2.8	890	1,400	3.3	3.3	5.2	8	215
M2 × 2.5	1.1	1.6	2.8	1,310	2,440	7.7	7.7	9	14	215
M3 × 3.0	1.3	2.2	3.3	1,570	2,495	6.4	6.4	11.7	18	301
M3 × 3.0	1.3	2.2	3.3	2,135	3,880	12.4	12.4	18.2	28	301
M3 × 3.5	1.3	3.2	4.3	2,308	3,465	12.9	12.9	21.5	34	602
M3 × 3.5	1.3	3.2	4.3	3,240	5,630	30.2	30.2	34.9	51	602
M3 × 5.5	1.8	3.3	4.3	3,810	5,590	27	27	43.6	61	930
M3 × 5.5	1.8	3.3	4.3	5,350	9,080	63.3	63.3	70	90	930

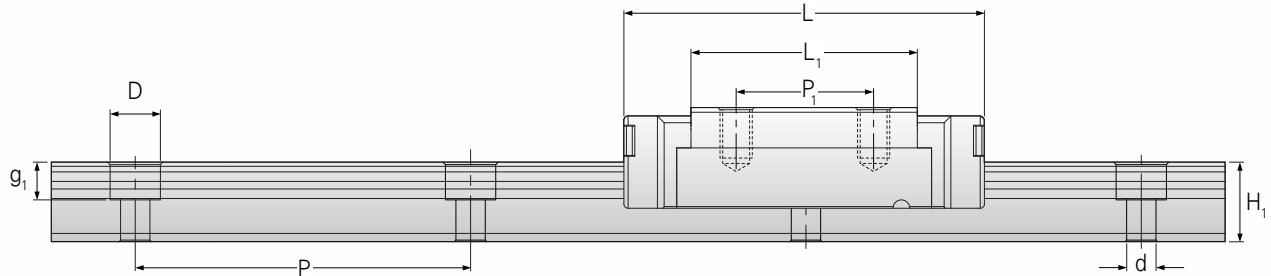

**STANDARD HMR-M** **ZZ - END SEAL, LUBRICATION STORAGE**  
**MN - STANDARD BLOCK LENGTH**  
**ML - LONG BLOCK LENGTH**  
**FOUR TAPPED HOLES**

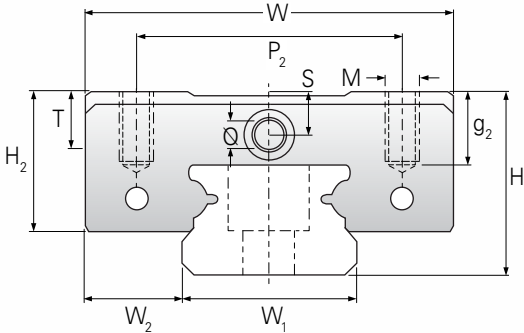

Model	FABRICATE DIMENSION		RAIL DIMENSIONS (mm)				BLOCK DIMENSIONS (mm)					
	Height	Width	W <sub>1</sub>	H <sub>1</sub>	P	D × d × g <sub>1</sub>	Width		Length			
	H	W <sub>2</sub>					W	L	L <sub>1</sub>	h <sub>2</sub>	P <sub>1</sub>	P <sub>2</sub>
HMR 3MN ZZ	4	2.5	3	2.6	10	M1.6	8	11.7	6.7	3.1	3.5	—
HMR 3ML ZZ	4	2.5	3	2.6	10	M1.6	8	16	10	3.1	5.5	—
HMR 5MN ZZ	6	3.5	5	3.5	15	3.5 × 2.4 × 1	12	16	10	4.5	—	8
HMR 5ML ZZ	6	3.5	5	3.5	15	3.5 × 2.4 × 1	12	19.6	13.5	4.5	7	—
HMR 7MN ZZ	8	5	7	4.7	15	4.2 × 2.4 × 2.3	17	23.7	14.3	6.5	8	12
HMR 7ML ZZ	8	5	7	4.7	15	4.2 × 2.4 × 2.3	17	31.2	21.8	6.5	13	12
HMR 9MN ZZ	10	5.5	9	5.5	20	6 × 3.5 × 3.5	20	30.6	20.5	7.8	10	15
HMR 9ML ZZ	10	5.5	9	5.5	20	6 × 3.5 × 3.5	20	40.9	30.8	7.8	16	15
HMR 12MN ZZ	13	7.5	12	7.5	25	6 × 3.5 × 4.5	27	35.4	22	10	15	20
HMR 12ML ZZ	13	7.5	12	7.5	25	6 × 3.5 × 4.5	27	47.6	34	10	20	20
HMR 15MN ZZ	16	8.5	15	9.5	40	6 × 3.5 × 4.5	32	43	27	12	20	25
HMR 15ML ZZ	16	8.5	15	9.5	40	6 × 3.5 × 4.5	32	60	44	12	25	25

Load capacities are calculated according to ISO 14728. To compare the rating life definition and the load capacities:  $C_{50} = 1.26 \times C_{100}$



BLOCK DIMENSIONS (mm)				BASIC LOAD RATINGS (N)		STATIC MOMENT RATINGS (Nm)			WEIGHT	
$M \times g_2$	$\varnothing$	S	T	Dynamic	Static				Block	Rail
				$C_{100}$	$C_0$	g	g/m			
M1.6 × 1.1	0.3	0.7	1.5	190	310	0.4	0.4	0.6	0.9	53
M2 × 1.1	0.3	0.7	1.5	295	575	1.1	1.1	0.9	1.2	53
M2 × 1.5	0.7	1.3	2	335	550	1	1	1.7	3.5	116
M2.6 × 2.0	0.7	1.3	2	470	900	2.1	2.1	2.4	4	116
M2 × 2.5	1.1	1.6	2.8	890	1,400	3.3	3.3	5.2	8	215
M2 × 2.5	1.1	1.6	2.8	1,310	2,440	7.7	7.7	9	14	215
M3 × 3.0	1.3	2.2	3.3	1,570	2,495	6.4	6.4	11.7	18	301
M3 × 3.0	1.3	2.2	3.3	2,135	3,880	12.4	12.4	18.2	28	301
M3 × 3.5	1.3	3.2	4.3	2,308	3,465	12.9	12.9	21.5	34	602
M3 × 3.5	1.3	3.2	4.3	3,240	5,630	30.2	30.2	34.9	51	602
M3 × 5.5	1.8	3.3	4.3	3,810	5,590	27	27	43.6	61	930
M3 × 5.5	1.8	3.3	4.3	5,350	9,080	63.3	63.3	70	90	930

**STANDARD HMR-M** **SUE - END SEAL, BOTTOM SEAL, REINFORCEMENT PLATE**  
**ZUE - END SEAL, BOTTOM SEAL, REINFORCEMENT PLATE, LUBRICATION STORAGE**  
**MN - STANDARD BLOCK LENGTH**  
**ML - LONG BLOCK LENGTH**  
**FOUR TAPPED HOLES**

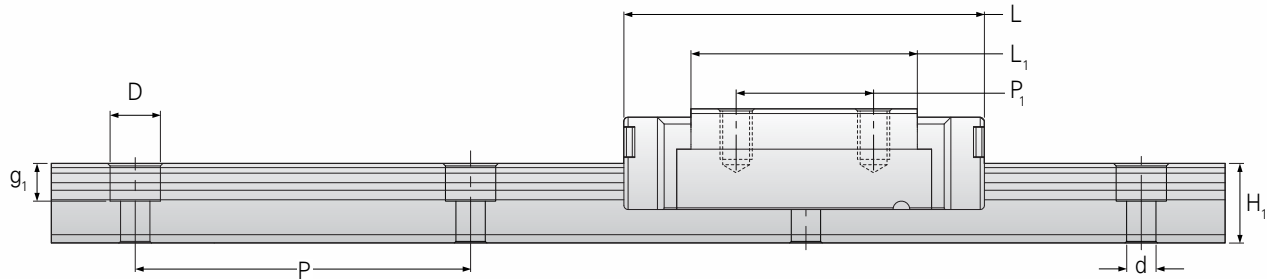





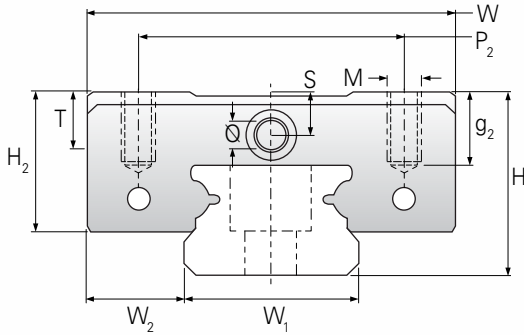

Model	FABRICATE DIMENSION		RAIL DIMENSIONS (mm)				BLOCK DIMENSIONS (mm)					
	Height	Width	W <sub>1</sub>	H <sub>1</sub>	P	D × d × g <sub>1</sub>	Width		Length			
	H	W <sub>2</sub>					W	L	L <sub>1</sub>	h <sub>2</sub>	P <sub>1</sub>	P <sub>2</sub>
HMR 5MN SUE	6	3.5	5	3.5	15	3.5 × 2.4 × 1	12	16.6	10	5	—	8
HMR 5ML SUE	6	3.5	5	3.5	15	3.5 × 2.4 × 1	12	20.2	13.5	5	7	—
HMR 9MN SUE	10	5.5	9	5.5	20	6 × 3.5 × 3.5	20	31.6	20.5	8.5	10	15
HMR 9ML SUE	10	5.5	9	5.5	20	6 × 3.5 × 3.5	20	41.9	30.8	8.5	16	15
HMR 12MN SUE	13	7.5	12	7.5	25	6 × 3.5 × 3.5	27	36.8	22	10.9	15	20
HMR 12ML SUE	13	7.5	12	7.5	25	6 × 3.5 × 3.5	27	49	34	10.9	20	20
HMR 15MN SUE	16	8.5	15	9.5	40	6 × 3.5 × 4.5	32	44.6	27	13.1	20	25
HMR 15ML SUE	16	8.5	15	9.5	40	6 × 3.5 × 4.5	32	61.6	44	13.1	25	25

Model	FABRICATE DIMENSION		RAIL DIMENSIONS (mm)				BLOCK DIMENSIONS (mm)					
	Height	Width	W <sub>1</sub>	H <sub>1</sub>	P	D × d × g <sub>1</sub>	Width		Length			
	H	W <sub>2</sub>					W	L	L <sub>1</sub>	h <sub>2</sub>	P <sub>1</sub>	P <sub>2</sub>
HMR 5MN ZUE	6	3.5	5	3.5	15	3.5 × 2.4 × 1	12	16.6	10	5	—	8
HMR 5ML ZUE	6	3.5	5	3.5	15	3.5 × 2.4 × 1	12	20.2	13.5	5	7	—
HMR 9MN ZUE	10	5.5	9	5.5	20	6 × 3.5 × 3.5	20	31.6	20.5	8.5	10	15
HMR 9ML ZUE	10	5.5	9	5.5	20	6 × 3.5 × 3.5	20	41.9	30.8	8.5	16	15
HMR 12MN ZUE	13	7.5	12	7.5	25	6 × 3.5 × 3.5	27	36.8	22	10.9	15	20
HMR 12ML ZUE	13	7.5	12	7.5	25	6 × 3.5 × 3.5	27	49	34	10.9	20	20
HMR 15MN ZUE	16	8.5	15	9.5	40	6 × 3.5 × 4.5	32	44.6	27	13.1	20	25
HMR 15ML ZUE	16	8.5	15	9.5	40	6 × 3.5 × 4.5	32	61.6	44	13.1	25	25

Load capacities are calculated according to ISO 14728. To compare the rating life definition and the load capacities:  $C_{50} = 1.26 \times C_{100}$



BLOCK DIMENSIONS (mm)				BASIC LOAD RATINGS (N)		STATIC MOMENT RATINGS (Nm)			WEIGHT	
$M \times g_2$	$\varnothing$	S	T	Dynamic	Static				Block	Rail
				$C_{100}$	$C_0$	g	g/m			
M2 × 1.5	0.7	1.3	2	335	550	1	1	1.7	3.5	116
M2.6 × 2.0	0.7	1.3	2	470	900	2.1	2.1	2.4	4	116
M3 × 3.0	1.3	2.2	3.3	1,570	2,495	6.4	6.4	11.7	18	301
M3 × 3.0	1.3	2.2	3.3	2,135	3,880	12.4	12.4	18.2	28	301
M3 × 3.5	1.3	3.2	4.3	2,308	3,465	12.9	12.9	21.5	34	602
M3 × 3.5	1.3	3.2	4.3	3,240	5,630	30.2	30.2	34.9	51	602
M3 × 5.5	1.8	3.3	4.3	3,810	5,590	27	27	43.6	61	930
M3 × 5.5	1.8	3.3	4.3	5,350	9,080	63.3	63.3	70	90	930

BLOCK DIMENSIONS (mm)				BASIC LOAD RATINGS (N)		STATIC MOMENT RATINGS (Nm)			WEIGHT	
$M \times g_2$	$\varnothing$	S	T	Dynamic	Static				Block	Rail
				$C_{100}$	$C_0$	g	g/m			
M2 × 1.5	0.7	1.3	2	335	550	1	1	1.7	3.5	116
M2.6 × 2.0	0.7	1.3	2	470	900	2.1	2.1	2.4	4	116
M3 × 3.0	1.3	2.2	3.3	1,570	2,495	6.4	6.4	11.7	18	301
M3 × 3.0	1.3	2.2	3.3	2,135	3,880	12.4	12.4	18.2	28	301
M3 × 3.5	1.3	3.2	4.3	2,308	3,465	12.9	12.9	21.5	34	602
M3 × 3.5	1.3	3.2	4.3	3,240	5,630	30.2	30.2	34.9	51	602
M3 × 5.5	1.8	3.3	4.3	3,810	5,590	27	27	43.6	61	930
M3 × 5.5	1.8	3.3	4.3	5,350	9,080	63.3	63.3	70	90	930

**STANDARD HMR-M** **EE - END SEAL, REINFORCEMENT PLATE**  
**EZ - END SEAL, REINFORCEMENT PLATE, LUBRICATION STORAGE**  
**MN - STANDARD BLOCK LENGTH**  
**ML - LONG BLOCK LENGTH**  
**FOUR TAPPED HOLES**

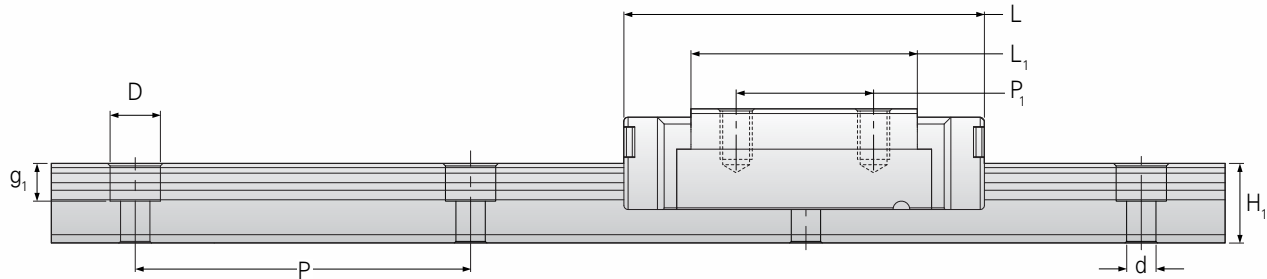





Model	FABRICATE DIMENSION		RAIL DIMENSIONS (mm)				BLOCK DIMENSIONS (mm)					
	Height	Width	W <sub>1</sub>	H <sub>1</sub>	P	D × d × g <sub>1</sub>	Width		Length			
	H	W <sub>2</sub>					W	L	L <sub>1</sub>	h <sub>2</sub>	P <sub>1</sub>	P <sub>2</sub>
HMR 5MN EE	6	3.5	5	3.5	15	3.5 × 2.4 × 1	12	16.6	10	4.9	—	8
HMR 5ML EE	6	3.5	5	3.5	15	3.5 × 2.4 × 1	12	20.2	13.5	4.9	7	—
HMR 9MN EE	10	5.5	9	5.5	20	6 × 3.5 × 3.5	20	31.6	20.5	8.3	10	15
HMR 9ML EE	10	5.5	9	5.5	20	6 × 3.5 × 3.5	20	41.9	30.8	8.3	16	15
HMR 12MN EE	13	7.5	12	7.5	25	6 × 3.5 × 3.5	27	36.8	22	10.7	15	20
HMR 12ML EE	13	7.5	12	7.5	25	6 × 3.5 × 3.5	27	49	34	10.7	20	20
HMR 15MN EE	16	8.5	15	9.5	40	6 × 3.5 × 4.5	32	44.6	27	12.8	20	25
HMR 15ML EE	16	8.5	15	9.5	40	6 × 3.5 × 4.5	32	61.6	44	12.8	25	25

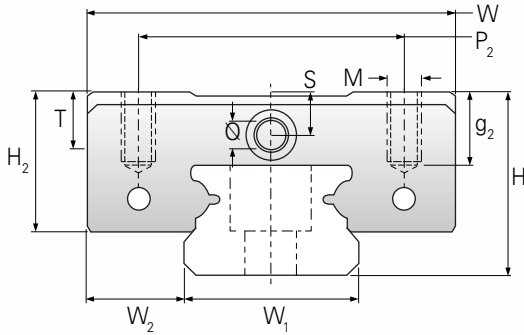

Model	FABRICATE DIMENSION		RAIL DIMENSIONS (mm)				BLOCK DIMENSIONS (mm)					
	Height	Width	W <sub>1</sub>	H <sub>1</sub>	P	D × d × g <sub>1</sub>	Width		Length			
	H	W <sub>2</sub>					W	L	L <sub>1</sub>	h <sub>2</sub>	P <sub>1</sub>	P <sub>2</sub>
HMR 5MN EZ	6	3.5	5	3.5	15	3.5 × 2.4 × 1	12	16.6	10	4.9	—	8
HMR 5ML EZ	6	3.5	5	3.5	15	3.5 × 2.4 × 1	12	20.2	13.5	4.9	7	—
HMR 9MN EZ	10	5.5	9	5.5	20	6 × 3.5 × 3.5	20	31.6	20.5	8.3	10	15
HMR 9ML EZ	10	5.5	9	5.5	20	6 × 3.5 × 3.5	20	41.9	30.8	8.3	16	15
HMR 12MN EZ	13	7.5	12	7.5	25	6 × 3.5 × 3.5	27	36.8	22	10.7	15	20
HMR 12ML EZ	13	7.5	12	7.5	25	6 × 3.5 × 3.5	27	49	34	10.7	20	20
HMR 15MN EZ	16	8.5	15	9.5	40	6 × 3.5 × 4.5	32	44.6	27	12.8	20	25
HMR 15ML EZ	16	8.5	15	9.5	40	6 × 3.5 × 4.5	32	61.6	44	12.8	25	25

Load capacities are calculated according to ISO 14728. To compare the rating life definition and the load capacities:  $C_{50} = 1.26 \times C_{100}$





BLOCK DIMENSIONS (mm)				BASIC LOAD RATINGS (N)		STATIC MOMENT RATINGS (Nm)			WEIGHT	
$M \times g_2$	$\varnothing$	S	T	Dynamic	Static				Block	Rail
				$C_{100}$	$C_0$	g	g/m			
M2 × 1.5	0.7	1.3	2	335	550	1	1	1.7	3.5	116
M2.6 × 2.0	0.7	1.3	2	470	900	2.1	2.1	2.4	4	116
M3 × 3.0	1.3	2.2	3.3	1,570	2,495	6.4	6.4	11.7	18	301
M3 × 3.0	1.3	2.2	3.3	2,135	3,880	12.4	12.4	18.2	28	301
M3 × 3.5	1.3	3.2	4.3	2,308	3,465	12.9	12.9	21.5	34	602
M3 × 3.5	1.3	3.2	4.3	3,240	5,630	30.2	30.2	34.9	51	602
M3 × 5.5	1.8	3.3	4.3	3,810	5,590	27	27	43.6	61	930
M3 × 5.5	1.8	3.3	4.3	5,350	9,080	63.3	63.3	70	90	930

BLOCK DIMENSIONS (mm)				BASIC LOAD RATINGS (N)		STATIC MOMENT RATINGS (Nm)			WEIGHT	
$M \times g_2$	$\varnothing$	S	T	Dynamic	Static				Block	Rail
				$C_{100}$	$C_0$	g	g/m			
M2 × 1.5	0.7	1.3	2	335	550	1	1	1.7	3.5	116
M2.6 × 2.0	0.7	1.3	2	470	900	2.1	2.1	2.4	4	116
M3 × 3.0	1.3	2.2	3.3	1,570	2,495	6.4	6.4	11.7	18	301
M3 × 3.0	1.3	2.2	3.3	2,135	3,880	12.4	12.4	18.2	28	301
M3 × 3.5	1.3	3.2	4.3	2,308	3,465	12.9	12.9	21.5	34	602
M3 × 3.5	1.3	3.2	4.3	3,240	5,630	30.2	30.2	34.9	51	602
M3 × 5.5	1.8	3.3	4.3	3,810	5,590	27	27	43.6	61	930
M3 × 5.5	1.8	3.3	4.3	5,350	9,080	63.3	63.3	70	90	930

**WIDE HMR-W** **SU - END SEAL, BOTTOM SEAL**  
**WN - STANDARD BLOCK LENGTH**  
**WL - LONG BLOCK LENGTH**  
**FOUR TAPPED HOLES**

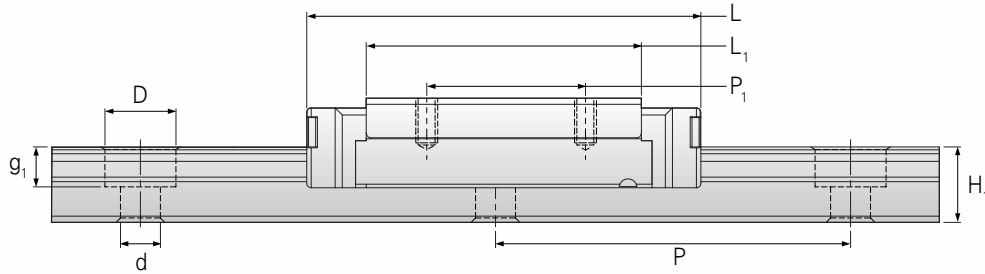

Model	DIMENSION		RAIL DIMENSIONS (mm)					BLOCK DIMENSIONS (mm)					
	Height H	Width W <sub>2</sub>	W <sub>1</sub>	H <sub>1</sub>	P	P <sub>3</sub>	D × d × g <sub>1</sub>	Width W	Length L	L <sub>1</sub>	h <sub>2</sub>	P <sub>1</sub>	P <sub>2</sub>
HMR 2WL SU*	4	3	4	3	10	—	2.8 × 1.8 × 1	10	17	11.9	3.1	6.5	—
HMR 3WN SU*	4.5	3	6	2.7	15	—	4 × 2.4 × 1.5	12	15	10	3.6	4.5	—
HMR 3WL SU*	4.5	3	6	2.7	15	—	4 × 2.4 × 1.5	12	20.1	15.1	3.6	8	—
HMR 5WN SU*	6.5	3.5	10	4	20	—	5.5 × 3 × 1.6	17	21.1	15.1	5.1	6.5	13
HMR 5WL SU*	6.5	3.5	10	4	20	—	5.5 × 3 × 1.6	17	27.2	21.2	5.1	11	13
HMR 7WN SU	9	5.5	14	5.2	30	—	6 × 3.5 × 3.5	25	31.6	21.2	7	10	19
HMR 7WL SU	9	5.5	14	5.2	30	—	6 × 3.5 × 3.5	25	40.5	30.1	7	19	19
HMR 9WN SU	12	6	18	7.3	30	—	6 × 3.5 × 3.5	30	39.1	27.9	8.6	12	21
HMR 9WL SU	12	6	18	7.3	30	—	6 × 3.5 × 3.5	30	50.7	39.5	8.6	24	23
HMR 12WN SU	14	8	24	8.5	40	—	8 × 4.5 × 4.5	40	44.4	31	10.1	15	28
HMR 12WL SU	14	8	24	8.5	40	—	8 × 4.5 × 4.5	40	59.4	46	10.1	28	28
HMR 15WN SU	16	9	42	9.5	40	23	8 × 4.5 × 4.5	60	55.3	38.5	12	20	45
HMR 15WL SU	16	9	42	9.5	40	23	8 × 4.5 × 4.5	60	74.4	57.6	12	35	45

**WIDE HMR-W** **SU - END SEAL, BOTTOM SEAL**  
**WNC - STANDARD BLOCK LENGTH**  
**WLC - LONG BLOCK LENGTH**

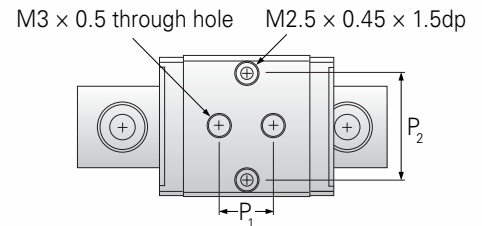

Model	DIMENSION		RAIL DIMENSIONS (mm)					BLOCK DIMENSIONS (mm)					
	Height H	Width W <sub>2</sub>	W <sub>1</sub>	H <sub>1</sub>	P	P <sub>3</sub>	D × d × g <sub>1</sub>	Width W	Length L	L <sub>1</sub>	h <sub>2</sub>	P <sub>1</sub>	P <sub>2</sub>
HMR 5WLC SU	6.5	3.5	10	4	20	—	5.5 × 3 × 1.6	17	27.2	21.2	5.1	11	13
HMR 5WNC SU	6.5	3.5	10	4	20	—	5.5 × 3 × 1.6	17	21.1	15.1	5.1	6.5	13

Load capacities are calculated according to ISO 14728. To compare the rating life definition and the load capacities:  $C_{50} = 1.26 \times C_{100}$

NOTE: WNC and WLC are replacements for IKO and THK.

# LINEAR GUIDANCE

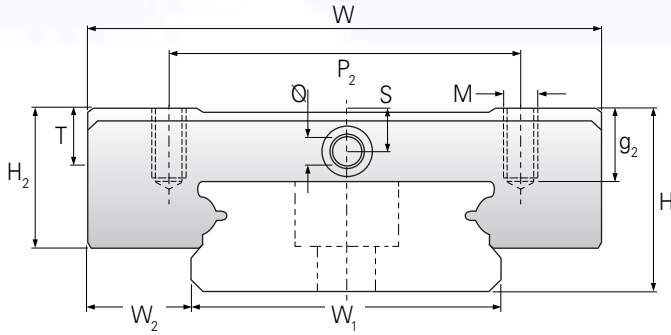

## MINIATURE GUIDES



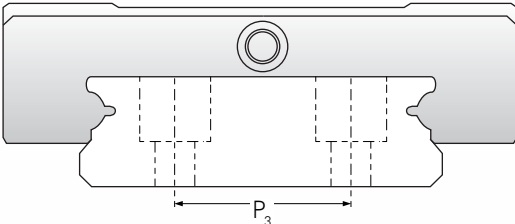

One Mounting Hole (HMR 3W–HMR 12W)



Two Mounting Holes (HMR 15W)

BLOCK DIMENSIONS (mm)				BASIC LOAD RATINGS (N)		STATIC MOMENT RATINGS (Nm)			WEIGHT	
$M \times g_2$	$\varnothing$	S	T	Dynamic	Static				Block	Rail
				$C_{100}$	$C_0$	g	g/m			
M2 × 1.3	—	—	1.3	310	625	1.2	1.2	1.6	3.0	69
M2 × 1.4	0.3	0.8	1.8	280	530	0.9	0.9	1.6	3.4	105
M2 × 1.4	0.3	0.8	1.8	370	800	1.9	1.9	2.5	3.4	105
M2.5 × 1.5	0.9	1.2	2.3	475	900	2.2	2.2	4.6	6	280
M2.5 × 1.5	0.9	1.2	2.3	615	1,315	4.1	4.1	6.8	8	280
M3 × 3	1.1	1.9	3.2	1,180	2,095	7.3	7.3	15	19	516
M3 × 3	1.1	1.9	3.2	1,570	3,140	14.9	14.9	22.65	27	516
M3 × 3	1.3	2.6	4	2,030	3,605	13.7	13.7	33.2	37	940
M3 × 3	1.3	2.6	4	2,550	4,990	26.7	26.7	45.9	51	940
M3 × 3.5	1.3	2.8	4.5	3,065	5,200	26.3	26.3	63.7	65	1,472
M3 × 3.5	1.3	2.8	4.5	4,070	7,800	56.4	56.4	95.6	93	1,472
M4 × 4.5	1.8	3.3	4.5	5,065	8,385	45.7	45.7	171.7	137	2,818
M4 × 4.5	1.8	3.3	4.5	6,725	12,580	93.1	93.1	257.6	200	2,818

BLOCK DIMENSIONS (mm)				BASIC LOAD RATINGS (N)		STATIC MOMENT RATINGS (Nm)			WEIGHT	
$M \times g_2$	$\varnothing$	S	T	Dynamic	Static				Block	Rail
				$C_{100}$	$C_0$	g	g/m			
M3 / M2.5 × 1.5	0.9	1.2	2.3	615	1,315	4.1	4.1	6.8	8	280
M3 / M2.5 × 1.5	0.9	1.2	2.3	475	900	2.2	2.2	4.6	6	280

**WIDE HMR-W ZU - END SEAL, BOTTOM SEAL, LUBRICATION STORAGE**  
**WN - STANDARD BLOCK LENGTH**  
**WL - LONG BLOCK LENGTH**  
**FOUR TAPPED HOLES**

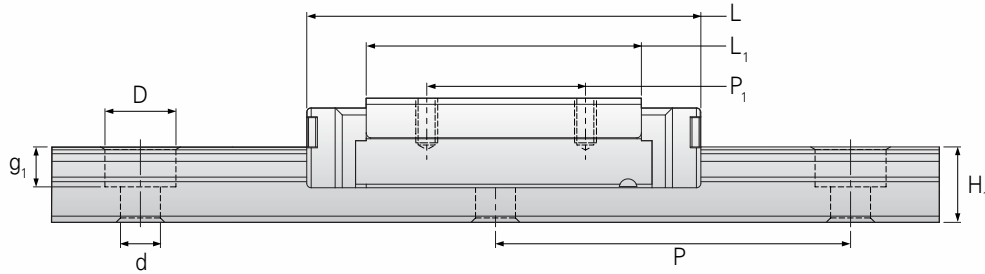

Model	DIMENSION		RAIL DIMENSIONS (mm)					BLOCK DIMENSIONS (mm)					
	Height H	Width W <sub>2</sub>	W <sub>1</sub>	H <sub>1</sub>	P	P <sub>3</sub>	D × d × g <sub>1</sub>	Width W	Length				
HMR 2WL ZU*	4	3	4	3	10	—	2.8 × 1.8 × 1	10	17	11.9	3.1	6.5	—
HMR 3WN ZU*	4.5	3	6	2.7	15	—	4 × 2.4 × 1.5	12	15	10	3.6	4.5	—
HMR 3WL ZU*	4.5	3	6	2.7	15	—	4 × 2.4 × 1.5	12	20.1	15.1	3.6	8	—
HMR 5WN ZU*	6.5	3.5	10	4	20	—	5.5 × 3 × 1.6	17	21.1	15.1	5.1	6.5	13
HMR 5WL ZU*	6.5	3.5	10	4	20	—	5.5 × 3 × 1.6	17	27.2	21.2	5.1	11	13
HMR 7WN ZU	9	5.5	14	5.2	30	—	6 × 3.5 × 3.5	25	31.6	21.2	7	10	19
HMR 7WL ZU	9	5.5	14	5.2	30	—	6 × 3.5 × 3.5	25	40.5	30.1	7	19	19
HMR 9WN ZU	12	6	18	7.3	30	—	6 × 3.5 × 3.5	30	39.1	27.9	8.6	12	21
HMR 9WL ZU	12	6	18	7.3	30	—	6 × 3.5 × 3.5	30	50.7	39.5	8.6	24	23
HMR 12WN ZU	14	8	24	8.5	40	—	8 × 4.5 × 4.5	40	44.4	31	10.1	15	28
HMR 12WL ZU	14	8	24	8.5	40	—	8 × 4.5 × 4.5	40	59.4	46	10.1	28	28
HMR 15WN ZU	16	9	42	9.5	40	23	8 × 4.5 × 4.5	60	55.3	38.5	12	20	45
HMR 15WL ZU	16	9	42	9.5	40	23	8 × 4.5 × 4.5	60	74.4	57.6	12	35	45

**WIDE HMR-W ZU - END SEAL, BOTTOM SEAL, LUBRICATION STORAGE**  
**WNC - STANDARD BLOCK LENGTH**  
**WLC - LONG BLOCK LENGTH**

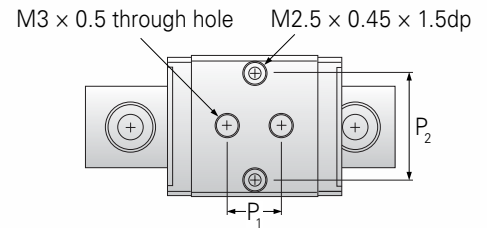

Model	DIMENSION		RAIL DIMENSIONS (mm)					BLOCK DIMENSIONS (mm)					
	Height H	Width W <sub>2</sub>	W <sub>1</sub>	H <sub>1</sub>	P	P <sub>3</sub>	D × d × g <sub>1</sub>	Width W	Length				
HMR 5WLC ZU	6.5	3.5	10	4	20	—	5.5 × 3 × 1.6	17	27.2	21.2	5.1	11	13
HMR 5WNC ZU	6.5	3.5	10	4	20	—	5.5 × 3 × 1.6	17	21.1	15.1	5.1	6.5	13

Load capacities are calculated according to ISO 14728. To compare the rating life definition and the load capacities:  $C_{50} = 1.26 \times C_{100}$

NOTE: WNC and WLC are replacements for IKO and THK.

# LINEAR GUIDANCE MINIATURE GUIDES

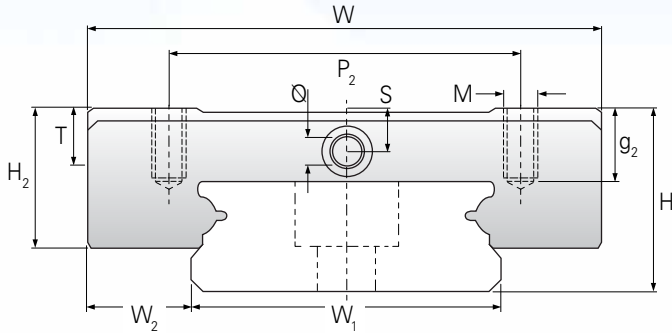

One Mounting Hole (HMR 3W–HMR 12W)

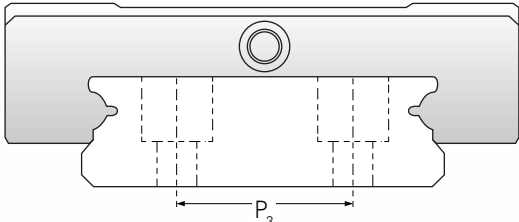

Two Mounting Holes (HMR 15W)

BLOCK DIMENSIONS (mm)				BASIC LOAD RATINGS (N)		STATIC MOMENT RATINGS (Nm)			WEIGHT	
$M \times g_2$	$\varnothing$	S	T	Dynamic	Static				Block	Rail
				$C_{100}$	$C_0$				g	g/m
M2 × 1.3	—	—	1.3	310	625	1.2	1.2	1.6	3.0	69
M2 × 1.4	0.3	0.8	1.8	280	530	0.9	0.9	1.6	3.4	105
M2 × 1.4	0.3	0.8	1.8	370	800	1.9	1.9	2.5	3.4	105
M2.5 × 1.5	0.9	1.2	2.3	475	900	2.2	2.2	4.6	6	280
M2.5 × 1.5	0.9	1.2	2.3	615	1,315	4.1	4.1	6.8	8	280
M3 × 3	1.1	1.9	3.2	1,180	2,095	7.3	7.3	15	19	516
M3 × 3	1.1	1.9	3.2	1,570	3,140	14.9	14.9	22.65	27	516
M3 × 3	1.3	2.6	4	2,030	3,605	13.7	13.7	33.2	37	940
M3 × 3	1.3	2.6	4	2,550	4,990	26.7	26.7	45.9	51	940
M3 × 3.5	1.3	2.8	4.5	3,065	5,200	26.3	26.3	63.7	65	1,472
M3 × 3.5	1.3	2.8	4.5	4,070	7,800	56.4	56.4	95.6	93	1,472
M4 × 4.5	1.8	3.3	4.5	5,065	8,385	45.7	45.7	171.7	137	2,818
M4 × 4.5	1.8	3.3	4.5	6,725	12,580	93.1	93.1	257.6	200	2,818

BLOCK DIMENSIONS (mm)				BASIC LOAD RATINGS (N)		STATIC MOMENT RATINGS (Nm)			WEIGHT	
$M \times g_2$	$\varnothing$	S	T	Dynamic	Static				Block	Rail
				$C_{100}$	$C_0$				g	g/m
M3 / M2.5 × 1.5	0.9	1.2	2.3	615	1,315	4.1	4.1	6.8	8	280
M3 / M2.5 × 1.5	0.9	1.2	2.3	475	900	2.2	2.2	4.6	6	280

The specifications and data in this publication are believed to be accurate and reliable. However, it is the responsibility of the product user to determine the suitability of Helix Linear Technologies products for a specific application. While defective products will be replaced without charge if promptly returned, no liability is assumed beyond such replacement.

**WIDE HMR-W SS - END SEAL**  
**WN - STANDARD BLOCK LENGTH**  
**WL - LONG BLOCK LENGTH**  
**FOUR TAPPED HOLES**

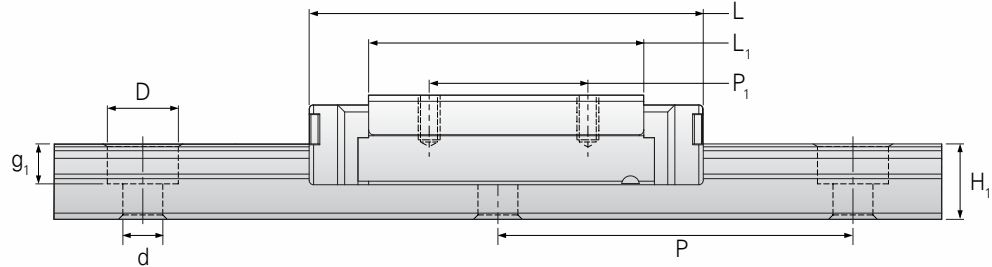

Model	DIMENSION		RAIL DIMENSIONS (mm)					BLOCK DIMENSIONS (mm)					
	Height H	Width W <sub>2</sub>	W <sub>1</sub>	H <sub>1</sub>	P	P <sub>3</sub>	D × d × g <sub>1</sub>	Width W	Length				
									L	L <sub>1</sub>	h <sub>2</sub>	P <sub>1</sub>	P <sub>2</sub>
HMR 2WL SS	4	3	4	3	10	—	2.8 × 1.8 × 1	10	17	11.9	3	6.5	—
HMR 3WN SS	4.5	3	6	2.7	15	—	4 × 2.4 × 1.5	12	15	10	3.5	4.5	—
HMR 3WL SS	4.5	3	6	2.7	15	—	4 × 2.4 × 1.5	12	20.1	15.1	3.5	8	—
HMR 5WN SS	6.5	3.5	10	4	20	—	5.5 × 3 × 1.6	17	21.1	15.1	5	6.5	13
HMR 5WL SS	6.5	3.5	10	4	20	—	5.5 × 3 × 1.6	17	27.2	21.2	5	11	13
HMR 7WN SS	9	5.5	14	5.2	30	—	6 × 3.5 × 3.5	25	31.6	21.2	7	10	19
HMR 7WL SS	9	5.5	14	5.2	30	—	6 × 3.5 × 3.5	25	40.5	30.1	7	19	19
HMR 9WN SS	12	6	18	7.3	30	—	6 × 3.5 × 3.5	30	39.1	27.9	8.6	12	21
HMR 9WL SS	12	6	18	7.3	30	—	6 × 3.5 × 3.5	30	50.7	39.5	8.6	24	23
HMR 12WN SS	14	8	24	8.5	40	—	8 × 4.5 × 4.5	40	44.4	31	10.1	15	28
HMR 12WL SS	14	8	24	8.5	40	—	8 × 4.5 × 4.5	40	59.4	46	10.1	28	28
HMR 15WN SS	16	9	42	9.5	40	23	8 × 4.5 × 4.5	60	55.3	38.5	12	20	45
HMR 15WL SS	16	9	42	9.5	40	23	8 × 4.5 × 4.5	60	74.4	57.6	12	35	45

**WIDE HMR-W SS - END SEAL**  
**WNC - STANDARD BLOCK LENGTH**  
**WLC - LONG BLOCK LENGTH**

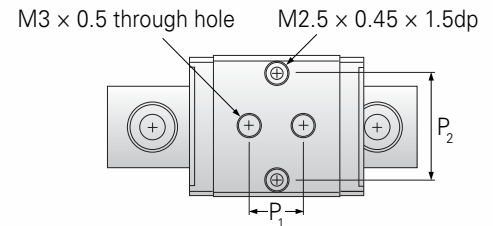

Model	DIMENSION		RAIL DIMENSIONS (mm)					BLOCK DIMENSIONS (mm)					
	Height H	Width W <sub>2</sub>	W <sub>1</sub>	H <sub>1</sub>	P	P <sub>3</sub>	D × d × g <sub>1</sub>	Width W	Length				
									L	L <sub>1</sub>	h <sub>2</sub>	P <sub>1</sub>	P <sub>2</sub>
HMR 5WLC SS	6.5	3.5	10	4	20	—	5.5 × 3 × 1.6	17	27.2	21.2	5	11	13
HMR 5WNC SS	6.5	3.5	10	4	20	—	5.5 × 3 × 1.6	17	21.1	15.1	5	6.5	13



Load capacities are calculated according to ISO 14728. To compare the rating life definition and the load capacities:  $C_{50} = 1.26 \times C_{100}$

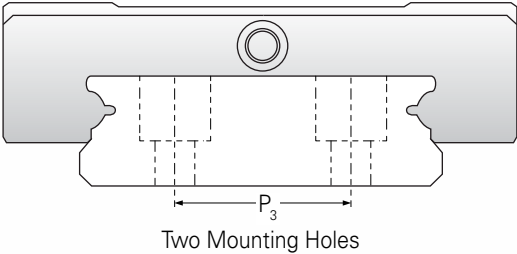
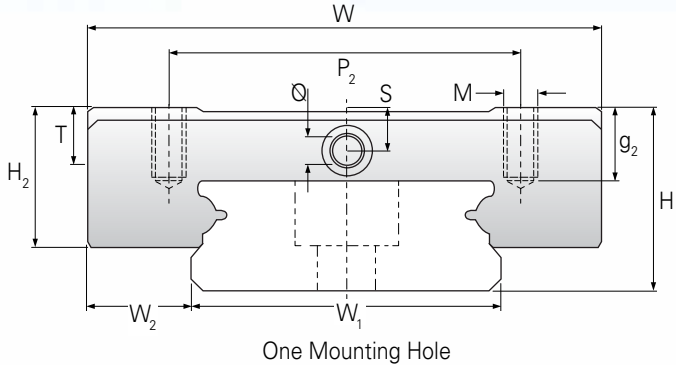

NOTE: WNC and WLC are replacements for IKO and THK.

# LINEAR GUIDANCE

## MINIATURE GUIDES



BLOCK DIMENSIONS (mm)				BASIC LOAD RATINGS (N)		STATIC MOMENT RATINGS (Nm)			WEIGHT	
M x g <sub>2</sub>	Ø	S	T	Dynamic	Static				Block	Rail
				C <sub>100</sub>	C <sub>0</sub>				g	g/m
M2 x 1.3	—	—	1.3	310	625	1.2	1.2	1.6	3.0	69
M2 x 1.4	0.3	0.8	1.8	280	530	0.9	0.9	1.6	3.4	105
M2 x 1.4	0.3	0.8	1.8	370	800	1.9	1.9	2.5	3.4	105
M2.5 x 1.5	0.9	1.2	2.3	475	900	2.2	2.2	4.6	6	280
M2.5 x 1.5	0.9	1.2	2.3	615	1,315	4.1	4.1	6.8	8	280
M3 x 3	1.1	1.9	3.2	1,180	2,095	7.3	7.3	15	19	516
M3 x 3	1.1	1.9	3.2	1,570	3,140	14.9	14.9	22.65	27	516
M3 x 3	1.3	2.6	4	2,030	3,605	13.7	13.7	33.2	37	940
M3 x 3	1.3	2.6	4	2,550	4,990	26.7	26.7	45.9	51	940
M3 x 3.5	1.3	3.1	4.5	3,065	5,200	26.3	26.3	63.7	65	1,472
M3 x 3.5	1.3	3.1	4.5	4,070	7,800	56.4	56.4	95.6	93	1,472
M4 x 4.5	1.8	3.3	4.5	5,065	8,385	45.7	45.7	171.7	137	2,818
M4 x 4.5	1.8	3.3	4.5	6,725	12,580	93.1	93.1	257.6	200	2,818

BLOCK DIMENSIONS (mm)				BASIC LOAD RATINGS (N)		STATIC MOMENT RATINGS (Nm)			WEIGHT	
M x g <sub>2</sub>	Ø	S	T	Dynamic	Static				Block	Rail
				C <sub>100</sub>	C <sub>0</sub>				g	g/m
M3 / M2.5 x 1.5	0.9	1.2	2.3	615	1,315	4.1	4.1	6.8	8	280
M3 / M2.5 x 1.5	0.9	1.2	2.3	475	900	2.2	2.2	4.6	6	280

**WIDE HMR-W** **ZZ - END SEAL, LUBRICATION STORAGE**  
**WN - STANDARD BLOCK LENGTH**  
**WL - LONG BLOCK LENGTH**  
**FOUR TAPPED HOLES**

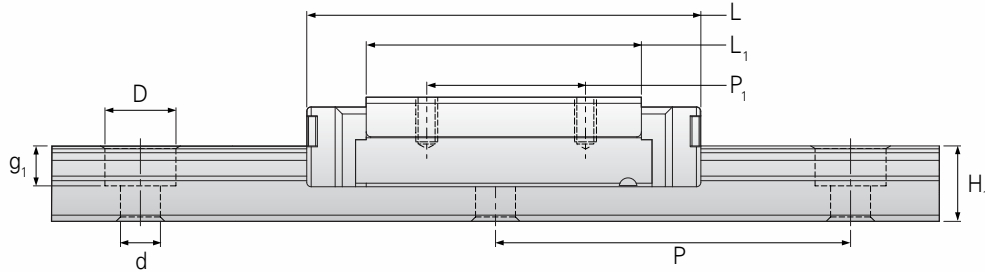

Model	DIMENSION		RAIL DIMENSIONS (mm)					BLOCK DIMENSIONS (mm)					
	Height H	Width W <sub>2</sub>	W <sub>1</sub>	H <sub>1</sub>	P	P <sub>3</sub>	D × d × g <sub>1</sub>	Width W	Length				
	H	W <sub>2</sub>	W <sub>1</sub>	H <sub>1</sub>	P	P <sub>3</sub>	D × d × g <sub>1</sub>	W	L	L <sub>1</sub>	h <sub>2</sub>	P <sub>1</sub>	P <sub>2</sub>
HMR 2WL ZZ*	4	3	4	3	10	—	2.8 × 1.8 × 1	10	17	11.9	3	6.5	—
HMR 3WN ZZ*	4.5	3	6	2.7	15	—	4 × 2.4 × 1.5	12	15	10	3.5	4.5	—
HMR 3WL ZZ*	4.5	3	6	2.7	15	—	4 × 2.4 × 1.5	12	20.1	15.1	3.5	8	—
HMR 5WN ZZ	6.5	3.5	10	4	20	—	5.5 × 3 × 1.6	17	21.1	15.1	5	6.5	13
HMR 5WL ZZ	6.5	3.5	10	4	20	—	5.5 × 3 × 1.6	17	27.2	21.2	5	11	13
HMR 7WN ZZ	9	5.5	14	5.2	30	—	6 × 3.5 × 3.5	25	31.6	21.2	7	10	19
HMR 7WL ZZ	9	5.5	14	5.2	30	—	6 × 3.5 × 3.5	25	40.5	30.1	7	19	19
HMR 9WN ZZ	12	6	18	7.3	30	—	6 × 3.5 × 3.5	30	39.1	27.9	8.6	12	21
HMR 9WL ZZ	12	6	18	7.3	30	—	6 × 3.5 × 3.5	30	50.7	39.5	8.6	24	23
HMR 12WN ZZ	14	8	24	8.5	40	—	8 × 4.5 × 4.5	40	44.4	31	10.1	15	28
HMR 12WL ZZ	14	8	24	8.5	40	—	8 × 4.5 × 4.5	40	59.4	46	10.1	28	28
HMR 15WN ZZ	16	9	42	9.5	40	23	8 × 4.5 × 4.5	60	55.3	38.5	12	20	45
HMR 15WL ZZ	16	9	42	9.5	40	23	8 × 4.5 × 4.5	60	74.4	57.6	12	35	45

\*Check availability

**WIDE HMR-W** **ZZ - END SEAL, LUBRICATION STORAGE**  
**WNC - STANDARD BLOCK LENGTH**  
**WLC - LONG BLOCK LENGTH**

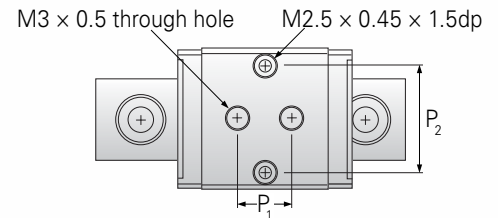

Model	DIMENSION		RAIL DIMENSIONS (mm)					BLOCK DIMENSIONS (mm)					
	Height H	Width W <sub>2</sub>	W <sub>1</sub>	H <sub>1</sub>	P	P <sub>3</sub>	D × d × g <sub>1</sub>	Width W	Length				
	H	W <sub>2</sub>	W <sub>1</sub>	H <sub>1</sub>	P	P <sub>3</sub>	D × d × g <sub>1</sub>	W	L	L <sub>1</sub>	h <sub>2</sub>	P <sub>1</sub>	P <sub>2</sub>
HMR 5WLC ZZ	6.5	3.5	10	4	20	—	5.5 × 3 × 1.6	17	27.2	21.2	5	11	13
HMR 5WNC ZZ	6.5	3.5	10	4	20	—	5.5 × 3 × 1.6	17	21.1	15.1	5	6.5	13

Load capacities are calculated according to ISO 14728. To compare the rating life definition and the load capacities:  $C_{50} = 1.26 \times C_{100}$

NOTE: WNC and WLC are replacements for IKO and THK.



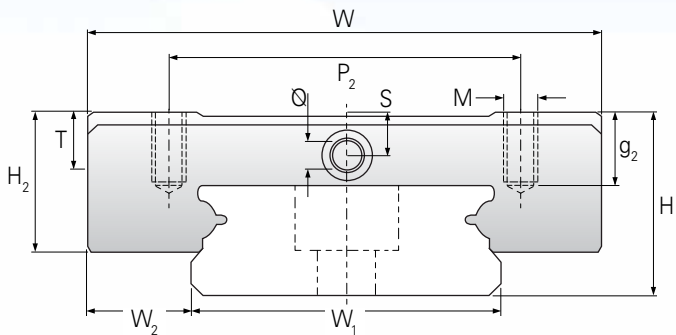

# LINEAR GUIDANCE MINIATURE GUIDES



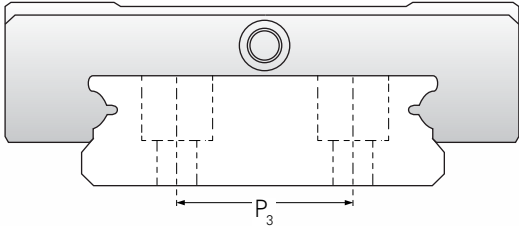

One Mounting Hole



Two Mounting Holes

BLOCK DIMENSIONS (mm)				BASIC LOAD RATINGS (N)		STATIC MOMENT RATINGS (Nm)			WEIGHT	
M × g <sub>2</sub>	Ø	S	T	Dynamic	Static				Block	Rail
				C <sub>100</sub>	C <sub>0</sub>				g	g/m
M2 × 1.3	—	—	1.3	310	625	1.2	1.2	1.6	3.0	69
M2 × 1.4	0.3	0.8	1.8	280	530	0.9	0.9	1.6	3.4	105
M2 × 1.4	0.3	0.8	1.8	370	800	1.9	1.9	2.5	3.4	105
M2.5 × 1.5	0.9	1.2	2.3	475	900	2.2	2.2	4.6	6	280
M2.5 × 1.5	0.9	1.2	2.3	615	1,315	4.1	4.1	6.8	8	280
M3 × 3	1.1	1.9	3.2	1,180	2,095	7.3	7.3	15	19	516
M3 × 3	1.1	1.9	3.2	1,570	3,140	14.9	14.9	22.65	27	516
M3 × 3	1.3	2.6	4	2,030	3,605	13.7	13.7	33.2	37	940
M3 × 3	1.3	2.6	4	2,550	4,990	26.7	26.7	45.9	51	940
M3 × 3.5	1.3	3.1	4.5	3,065	5,200	26.3	26.3	63.7	65	1,472
M3 × 3.5	1.3	3.1	4.5	4,070	7,800	56.4	56.4	95.6	93	1,472
M4 × 4.5	1.8	3.3	4.5	5,065	8,385	45.7	45.7	171.7	137	2,818
M4 × 4.5	1.8	3.3	4.5	6,725	12,580	93.1	93.1	257.6	200	2,818

BLOCK DIMENSIONS (mm)				BASIC LOAD RATINGS (N)		STATIC MOMENT RATINGS (Nm)			WEIGHT	
M × g <sub>2</sub>	Ø	S	T	Dynamic	Static				Block	Rail
				C <sub>100</sub>	C <sub>0</sub>				g	g/m
M3 / M2.5 × 1.5	0.9	1.2	2.3	615	1,315	4.1	4.1	6.8	8	280
M3 / M2.5 × 1.5	0.9	1.2	2.3	475	900	2.2	2.2	4.6	6	280

**WIDE HMR-W** SUE - END SEAL, BOTTOM SEAL, REINFORCEMENT PLATE  
 ZUE - END SEAL, BOTTOM SEAL, REINFORCEMENT PLATE, LUBRICATION STORAGE  
 MN - STANDARD BLOCK LENGTH  
 ML - LONG BLOCK LENGTH  
 FOUR TAPPED HOLES

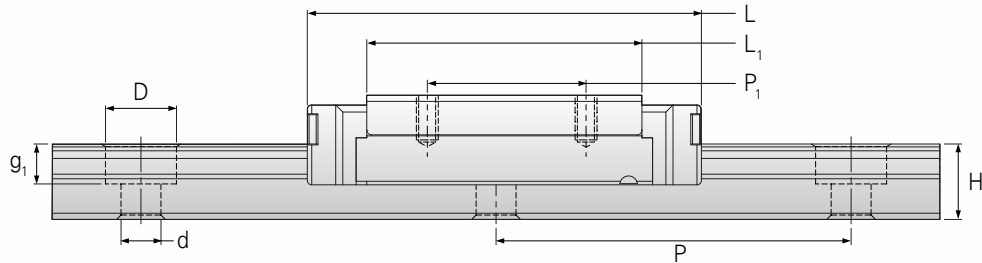

Model	DIMENSION		RAIL DIMENSIONS (mm)					BLOCK DIMENSIONS (mm)					
	Height H	Width W <sub>2</sub>	W <sub>1</sub>	H <sub>1</sub>	P	P <sub>3</sub>	D × d × g <sub>1</sub>	Width W	Length				
									L	L <sub>1</sub>	h <sub>2</sub>	P <sub>1</sub>	P <sub>2</sub>
HMR 2WL EE	4	3	4	3	10	—	2.8 × 1.8 × 1	10	17.5	11.9	3.3	6.5	—
HMR 7WN EE	9	5.5	14	5.2	30	—	6 × 3.5 × 4.5	25	32.5	21.2	7.5	10	19
HMR 7WL EE	9	5.5	14	5.2	30	—	6 × 3.5 × 4.5	25	41.5	30.1	7.5	19	19
HMR 9WN EE	12	6	18	7.3	30	—	6 × 3.5 × 4.5	30	40.2	27.9	9.2	12	21
HMR 9WL EE	12	6	18	7.3	30	—	6 × 3.5 × 4.5	30	51.8	39.5	9.2	24	23
HMR 12WN EE	14	8	24	8.5	40	—	8 × 4.5 × 4.5	40	45.8	31	10.7	15	28
HMR 12WL EE	14	8	24	8.5	40	—	8 × 4.5 × 4.5	40	60.8	46	10.7	28	28
HMR 15WN EE	16	9	42	9.5	40	23	8 × 4.5 × 4.5	60	56.9	38.5	12.8	20	45
HMR 15WL EE	16	9	42	9.5	40	23	8 × 4.5 × 4.5	60	76	57.6	12.8	35	45

Model	DIMENSION		RAIL DIMENSIONS (mm)					BLOCK DIMENSIONS (mm)					
	Height H	Width W <sub>2</sub>	W <sub>1</sub>	H <sub>1</sub>	P	P <sub>3</sub>	D × d × g <sub>1</sub>	Width W	Length				
									L	L <sub>1</sub>	h <sub>2</sub>	P <sub>1</sub>	P <sub>2</sub>
HMR 2WL EZ	4	3	4	3	10	—	2.8 × 1.8 × 1	10	17.5	11.9	3.3	6.5	—
HMR 7WN EZ	9	5.5	14	5.2	30	—	6 × 3.5 × 4.5	25	32.5	21.2	7.5	10	19
HMR 7WL EZ	9	5.5	14	5.2	30	—	6 × 3.5 × 4.5	25	41.5	30.1	7.5	19	19
HMR 9WN EZ	12	6	18	7.3	30	—	6 × 3.5 × 4.5	30	40.2	27.9	9.2	12	21
HMR 9WL EZ	12	6	18	7.3	30	—	6 × 3.5 × 4.5	30	51.8	39.5	9.2	24	23
HMR 12WN EZ	14	8	24	8.5	40	—	8 × 4.5 × 4.5	40	45.8	31	10.7	15	28
HMR 12WL EZ	14	8	24	8.5	40	—	8 × 4.5 × 4.5	40	60.8	46	10.7	28	28
HMR 15WN EZ	16	9	42	9.5	40	23	8 × 4.5 × 4.5	60	56.9	38.5	12.8	20	45
HMR 15WL EZ	16	9	42	9.5	40	23	8 × 4.5 × 4.5	60	76	57.6	12.8	35	45

Load capacities are calculated according to ISO 14728. To compare the rating life definition and the load capacities:  $C_{50} = 1.26 \times C_{100}$

# LINEAR GUIDANCE

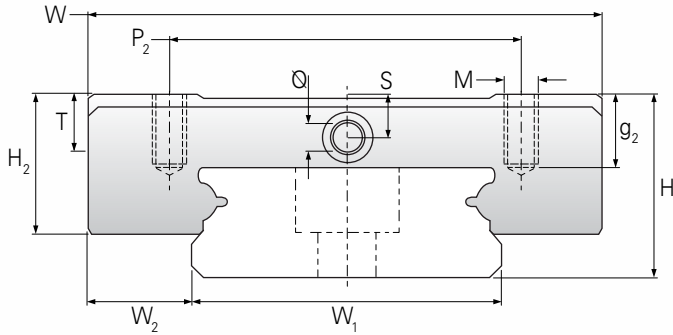

## MINIATURE GUIDES



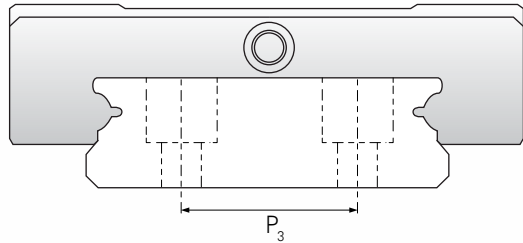

One Mounting Hole



Two Mounting Holes

BLOCK DIMENSIONS (mm)				BASIC LOAD RATINGS (N)		STATIC MOMENT RATINGS (Nm)			WEIGHT	
M × g <sub>2</sub>	Ø	S	T	Dynamic	Static				Block	Rail
				C <sub>100</sub>	C <sub>0</sub>	g	g/m			
M2 × 1.3	—	—	1.3	310	625	1.6	1.2	1.2	3.0	69
M3 × 3	1.1	1.9	3.2	1,180	2,095	15	7.3	7.3	19	516
M3 × 3	1.1	1.9	3.2	1,570	3,140	22.65	14.9	14.9	27	516
M3 × 3	1.3	2.6	4	2,030	3,605	33.2	13.7	13.7	37	940
M3 × 3	1.3	2.6	4	2,550	4,990	45.9	26.7	26.7	51	940
M3 × 3.5	1.3	3.1	4.5	3,065	5,200	63.7	26.3	26.3	68	1,472
M3 × 3.5	1.3	3.1	4.5	4,070	7,800	95.6	56.4	56.4	96	1,472
M3 × 4.5	1.8	3.3	4.5	5,065	8,385	171.7	45.7	45.7	140	2,818
M3 × 4.5	1.8	3.3	4.5	6,725	12,580	257.6	93.1	93.1	203	2,818

BLOCK DIMENSIONS (mm)				BASIC LOAD RATINGS (N)		STATIC MOMENT RATINGS (Nm)			WEIGHT	
M × g <sub>2</sub>	Ø	S	T	Dynamic	Static				Block	Rail
				C <sub>100</sub>	C <sub>0</sub>	g	g/m			
M2 × 1.3	—	—	1.3	310	625	1.6	1.2	1.2	3.0	69
M3 × 3	1.1	1.9	3.2	1,180	2,095	15	7.3	7.3	19	516
M3 × 3	1.1	1.9	3.2	1,570	3,140	22.65	14.9	14.9	27	516
M3 × 3	1.3	2.6	4	2,030	3,605	33.2	13.7	13.7	37	940
M3 × 3	1.3	2.6	4	2,550	4,990	45.9	26.7	26.7	51	940
M3 × 3.5	1.3	3.1	4.5	3,065	5,200	63.7	26.3	26.3	68	1,472
M3 × 3.5	1.3	3.1	4.5	4,070	7,800	95.6	56.4	56.4	96	1,472
M3 × 4.5	1.8	3.3	4.5	5,065	8,385	171.7	45.7	45.7	140	2,818
M3 × 4.5	1.8	3.3	4.5	6,725	12,580	257.6	93.1	93.1	203	2,818

## WIDE HMR-W

**EE - END SEAL, REINFORCEMENT PLATE**  
**EZ - END SEAL, REINFORCEMENT PLATE, LUBRICATION STORAGE**  
**MN - STANDARD BLOCK LENGTH**  
**ML - LONG BLOCK LENGTH**  
**FOUR TAPPED HOLES**

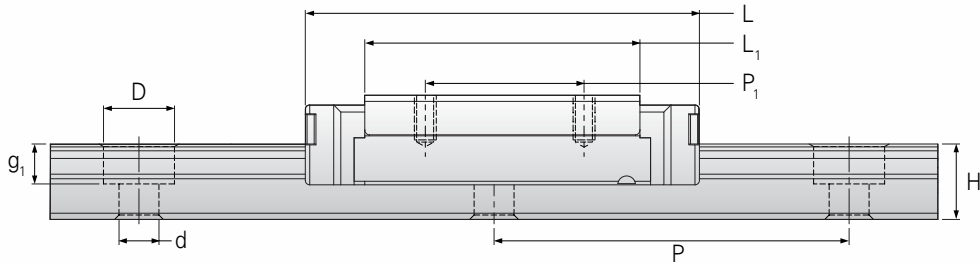

Model	DIMENSION		RAIL DIMENSIONS (mm)					BLOCK DIMENSIONS (mm)					
	Height H	Width W <sub>2</sub>	W <sub>1</sub>	H <sub>1</sub>	P	P <sub>3</sub>	D × d × g <sub>1</sub>	Width W	Length				
	H	W <sub>2</sub>	W <sub>1</sub>	H <sub>1</sub>	P	P <sub>3</sub>	D × d × g <sub>1</sub>	W	L	L <sub>1</sub>	h <sub>2</sub>	P <sub>1</sub>	P <sub>2</sub>
HMR 2WL SUE	4	3	4	3	10	—	2.8 × 1.8 × 1	10	17.5	11.9	3.3	6.5	—
HMR 7WN SUE	9	5.5	14	5.2	30	—	6 × 3.5 × 4.5	25	32.5	21.2	7.5	10	19
HMR 7WL SUE	9	5.5	14	5.2	30	—	6 × 3.5 × 4.5	25	41.5	30.1	7.5	19	19
HMR 9WN SUE	12	6	18	7.3	30	—	6 × 3.5 × 4.5	30	40.2	27.9	9.2	12	21
HMR 9WL SUE	12	6	18	7.3	30	—	6 × 3.5 × 4.5	30	51.8	39.5	9.2	24	23
HMR 12WN SUE	14	8	24	8.5	40	—	8 × 4.5 × 4.5	40	45.8	31	10.7	15	28
HMR 12WL SUE	14	8	24	8.5	40	—	8 × 4.5 × 4.5	40	60.8	46	10.7	28	28
HMR 15WN SUE	16	9	42	9.5	40	23	8 × 4.5 × 4.5	60	56.9	38.5	12.8	20	45
HMR 15WL SUE	16	9	42	9.5	40	23	8 × 4.5 × 4.5	60	76	57.6	12.8	35	45

Model	DIMENSION		RAIL DIMENSIONS (mm)					BLOCK DIMENSIONS (mm)					
	Height H	Width W <sub>2</sub>	W <sub>1</sub>	H <sub>1</sub>	P	P <sub>3</sub>	D × d × g <sub>1</sub>	Width W	Length				
	H	W <sub>2</sub>	W <sub>1</sub>	H <sub>1</sub>	P	P <sub>3</sub>	D × d × g <sub>1</sub>	W	L	L <sub>1</sub>	h <sub>2</sub>	P <sub>1</sub>	P <sub>2</sub>
HMR 2WL ZUE	4	3	4	3	10	—	2.8 × 1.8 × 1	10	17.5	11.9	3.3	6.5	—
HMR 7WN ZUE	9	5.5	14	5.2	30	—	6 × 3.5 × 4.5	25	32.5	21.2	7.5	10	19
HMR 7WL ZUE	9	5.5	14	5.2	30	—	6 × 3.5 × 4.5	25	41.5	30.1	7.5	19	19
HMR 9WN ZUE	12	6	18	7.3	30	—	6 × 3.5 × 4.5	30	40.2	27.9	9.2	12	21
HMR 9WL ZUE	12	6	18	7.3	30	—	6 × 3.5 × 4.5	30	51.8	39.5	9.2	24	23
HMR 12WN ZUE	14	8	24	8.5	40	—	8 × 4.5 × 4.5	40	45.8	31	10.7	15	28
HMR 12WL ZUE	14	8	24	8.5	40	—	8 × 4.5 × 4.5	40	60.8	46	10.7	28	28
HMR 15WN ZUE	16	9	42	9.5	40	23	8 × 4.5 × 4.5	60	56.9	38.5	12.8	20	45
HMR 15WL ZUE	16	9	42	9.5	40	23	8 × 4.5 × 4.5	60	76	57.6	12.8	35	45

Load capacities are calculated according to ISO 14728. To compare the rating life definition and the load capacities:  $C_{50} = 1.26 \times C_{100}$

# LINEAR GUIDANCE

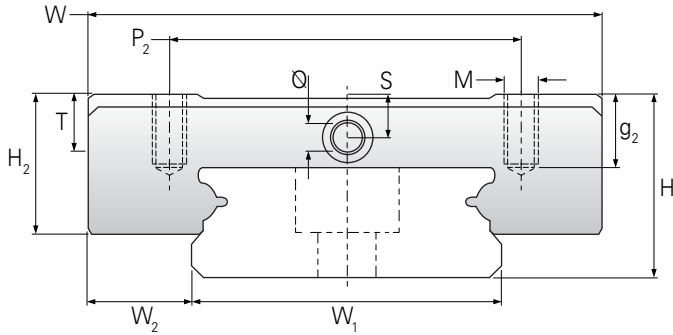

## MINIATURE GUIDES



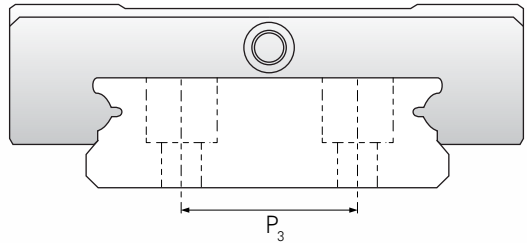

One Mounting Hole



Two Mounting Holes

BLOCK DIMENSIONS (mm)				BASIC LOAD RATINGS (N)		STATIC MOMENT RATINGS (Nm)			WEIGHT	
M × g <sub>2</sub>	Ø	S	T	Dynamic	Static				Block	Rail
				C <sub>100</sub>	C <sub>0</sub>	g	g/m			
M2 × 1.3	—	—	1.3	310	625	1.6	1.2	1.2	3.0	69
M3 × 3	1.1	1.9	3.2	1,180	2,095	15	7.3	7.3	19	516
M3 × 3	1.1	1.9	3.2	1,570	3,140	22.65	14.9	14.9	27	516
M3 × 3	1.3	2.6	4	2,030	3,605	33.2	13.7	13.7	37	940
M3 × 3	1.3	2.6	4	2,550	4,990	45.9	26.7	26.7	51	940
M3 × 3.5	1.3	3.1	4.5	3,065	5,200	63.7	26.3	26.3	68	1,472
M3 × 3.5	1.3	3.1	4.5	4,070	7,800	95.6	56.4	56.4	96	1,472
M3 × 4.5	1.8	3.3	4.5	5,065	8,385	171.7	45.7	45.7	140	2,818
M3 × 4.5	1.8	3.3	4.5	6,725	12,580	257.6	93.1	93.1	203	2,818

BLOCK DIMENSIONS (mm)				BASIC LOAD RATINGS (N)		STATIC MOMENT RATINGS (Nm)			WEIGHT	
M × g <sub>2</sub>	Ø	S	T	Dynamic	Static				Block	Rail
				C <sub>100</sub>	C <sub>0</sub>	g	g/m			
M2 × 1.3	—	—	1.3	310	625	1.6	1.2	1.2	3.0	69
M3 × 3	1.1	1.9	3.2	1,180	2,095	15	7.3	7.3	19	516
M3 × 3	1.1	1.9	3.2	1,570	3,140	22.65	14.9	14.9	27	516
M3 × 3	1.3	2.6	4	2,030	3,605	33.2	13.7	13.7	37	940
M3 × 3	1.3	2.6	4	2,550	4,990	45.9	26.7	26.7	51	940
M3 × 3.5	1.3	3.1	4.5	3,065	5,200	63.7	26.3	26.3	68	1,472
M3 × 3.5	1.3	3.1	4.5	4,070	7,800	95.6	56.4	56.4	96	1,472
M3 × 4.5	1.8	3.3	4.5	5,065	8,385	171.7	45.7	45.7	140	2,818
M3 × 4.5	1.8	3.3	4.5	6,725	12,580	257.6	93.1	93.1	203	2,818

*Our products make us industry leaders.  
Our people make us world class.*

Christopher M. Nook  
CEO  
Helix Linear Technologies, Inc.

