

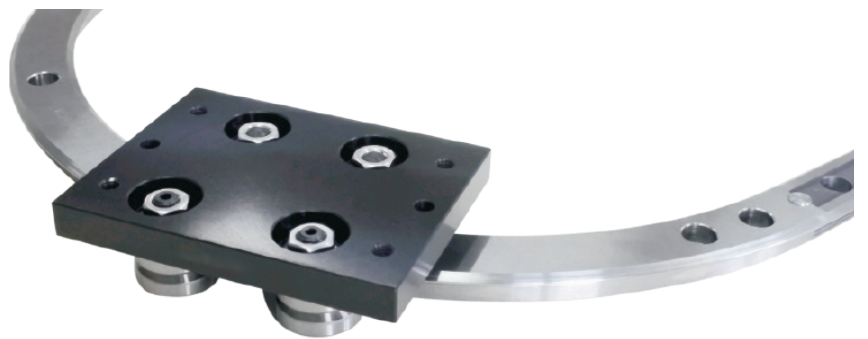

CURVE AND LINEAR TRACK



Helix Linear Technologies offers exceptional performance with the highest quality that our customers have come to expect.

We are proud to serve the following industries:

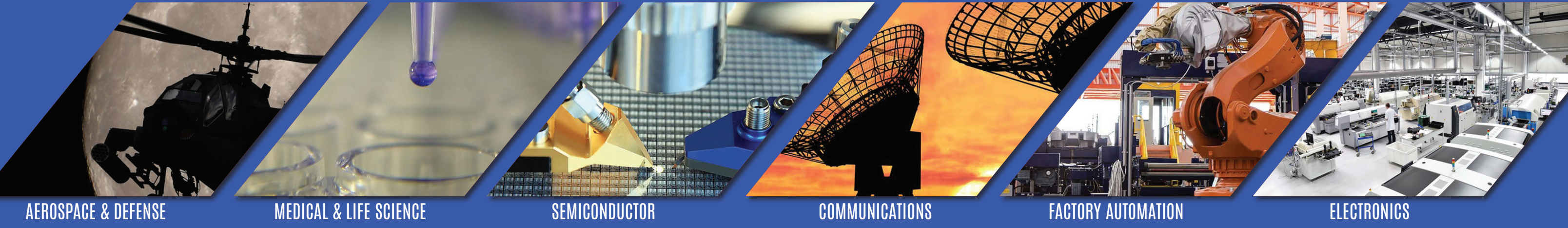

AEROSPACE & DEFENSE

MEDICAL & LIFE SCIENCE

SEMICONDUCTOR

COMMUNICATIONS

FACTORY AUTOMATION

ELECTRONICS



ADDITIVE MANUFACTURING

PACKAGING

CHEMICAL

FOOD & BEVERAGE

STEEL & METAL MANUFACTURING

AUTOMOTIVE

**HELIX LINEAR IS A GLOBAL LEADER
IN LINEAR MOTION TECHNOLOGIES.**

For nearly 50 years the company has helped its customers engineer their own success in a wide range of markets. Helix Linear leads with its innovative design, engineering, and manufacturing of precision linear motion and power transmission systems. Helix Linear focuses on engineering and manufacturing lead screws and linear actuators.



Strategy

Helix Linear Technologies produces cost-effective, precision linear motion systems and components using leading-edge technology, equipment and production methods.



Collaboration

For nearly 50 years Helix Linear Technologies has been innovating together with our customers to design, engineer and manufacture our wide range of products for a variety of markets.



Solutions

Full range of product solutions to fit all our customers performance needs; whether the application requires an off-the-shelf linear motion component or a custom engineered solution, Helix Linear Technologies offers exceptional performance with the highest quality.



Helix Linear Technologies is one of world recognized leaders in design and manufacturing of low friction linear motion components and precision bearings. Helix products are exported to over 30 countries and regions. We provide not only standard products, but also customized solutions. Helix means "Always reach for higher goals." Helix is committed to excellence and linear motion innovation while guaranteeing its customers the best pricing in our industry.

Helix actively seeks to work with you on your next design and we promise the following:

- The right product for your application
- A quality product you can trust
- Engineering assistance that is proven and world renown.

PARO TRACK SYSTEM

Helix provides a wide choice of sizes and options to build linear, ring and track motion system. All of components including linear guides, ring guides, bearings and lubricate parts are designed standard and modularized. Customer can select and build motion system easy and quickly.





LINEAR MOTION COMPONENTS

Construction

Please see below figure. This system includes Double Edge Space Rail, Concentric Bearing, Eccentric Bearing, Cap Seals and Lubricator. Rail, bearing and other components are designed interchangeable with all of international standard suppliers.

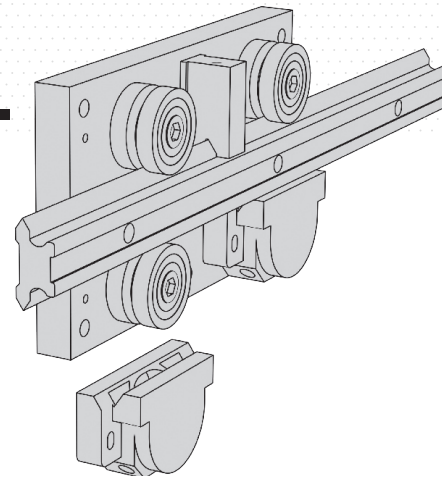

Double Edge Space Rail

- Made of European high quality bearing steel
- Deep hardened in working surfaces for high wear resistance
- Ground Double 70° V working edges together to ensure parallelism
- Soft rail body for customization machining process
- Provide 3 standard sizes for customer's selection
- Any length up to 5.5meters without connection
- Longer length (Unlimited) can be achieved by Connection
- Supply two precision types, ground and un-ground

Concentric / Eccentric Bearing

- Made of high quality bearing steel
- Whole body hardened for high wear resistance
- Supply Twin type and Double row type bearings (See figure)
- Long bolt for thick carriage block
- Short bolt for thin carriage block
- Concentric / Eccentric bolt supplied

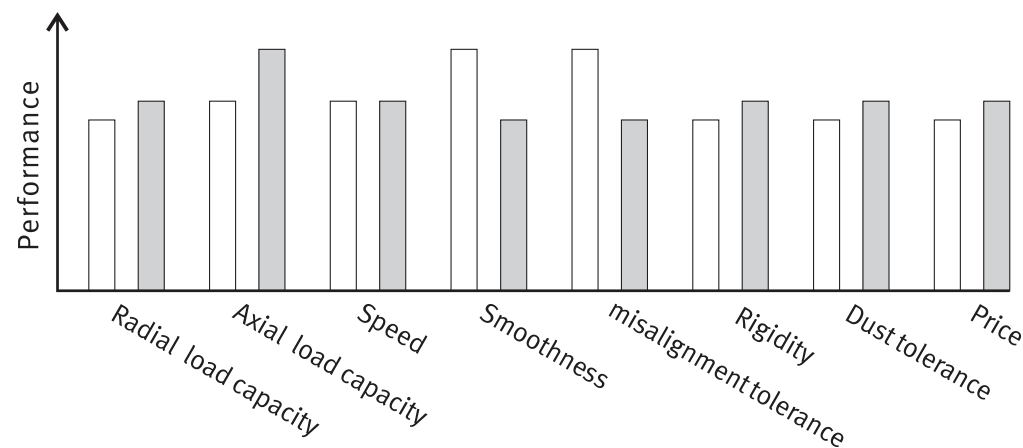
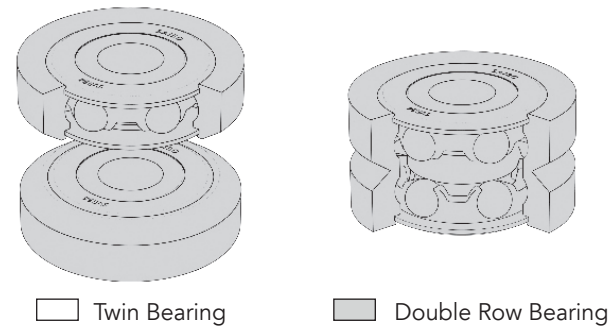

Cap Seal

- Protect bearing against dust
- Protect operator safety
- Lubricated felt wiper contact rail's working surface to increase load capacity and life
- Standard and interchangeable

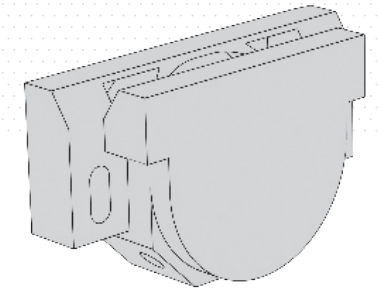

Lubricate Wiper

- Lubricated felt wiper contact rail's working surface to increase load capacity and life
- Lubricated felt wiper is pushed lightly by a small spring to ensure low friction with the rail's working surface
- Easy to fill lubricate oil from its fill hole
- Standard and interchangeable

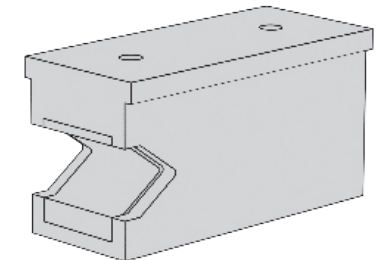

Precision Grade

Helix provides two grades of precision. P1 ground and P3 unground. Here we must emphasize that P3 grade's motion is also very smooth and stable. It is fit for smooth running without very high precision and low cost request. But when linear rail connect ring rail, it must be P1 grade.

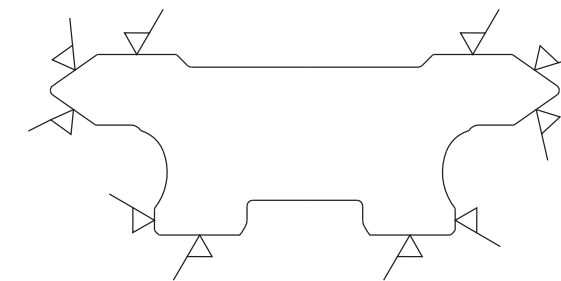

P1 Grade
✓ Means Ground Surface

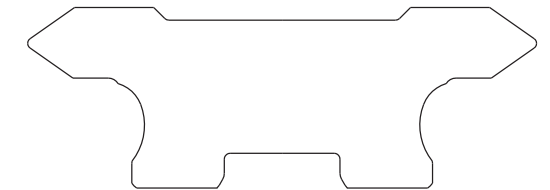

P3 Grade

The specifications and data in this publication are believed to be accurate and reliable. However, it is the responsibility of the product user to determine the suitability of Helix products for a specific application. While defective products will be replaced without charge if promptly returned, no liability is assumed beyond such replacement.



Full Size Overview

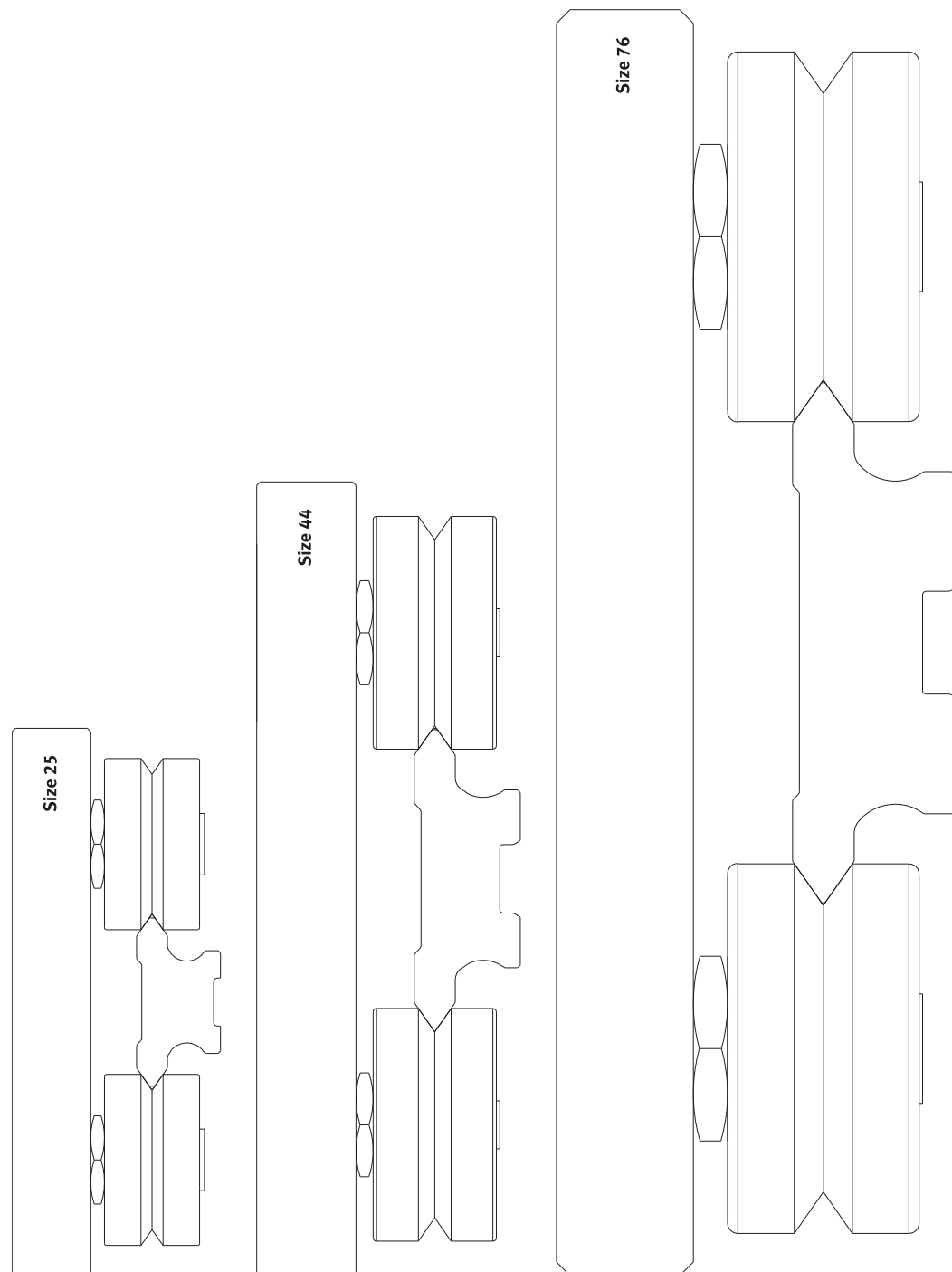

Assembly

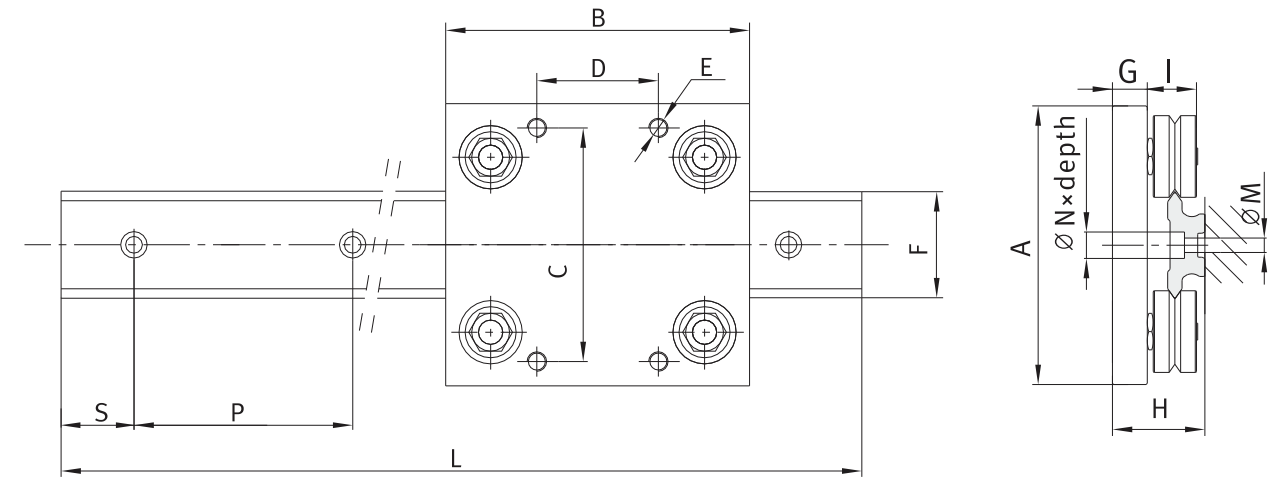

Railway	Carriage	Dimensions						
		A	B	C	D	E	F	G
SB-LGV25XL	SB-SLC25A		80		24	4XM6	25	11.5
	SB-SLC25B	80	135	65	60	6XM6		
	SB-SLC25C		180		82	6XM6		
SB-LGV44XL	SB-SLC44A	116	125		50	4XM8	44	14.5
	SB-SLC44B		180	96	80	6XM8		
	SB-SLC44C		225		103	6XM8		
SB-LGV76XL	SB-SLC76A	185	200		90	4XM10	76	20
	SB-SLC76B		300	160	135	6XM10		
	SB-SLC76C		400		185	6XM10		

Dimensions												
P1		P3		I	M	NxDepth	P	S	P1		H	
30.5		30.85		16.5	5.5	10x5.5	90	45	1500		5500	
38.5		38.85		21	7	11x7	90	45	20		4055	
58.5		58.85		33.5	11	20x12	90	45	20		4794	

The specifications and data in this publication are believed to be accurate and reliable. However, it is the responsibility of the product user to determine the suitability of Helix products for a specific application. While defective products will be replaced without charge if promptly returned, no liability is assumed beyond such replacement.



COMPONENTS

Railway

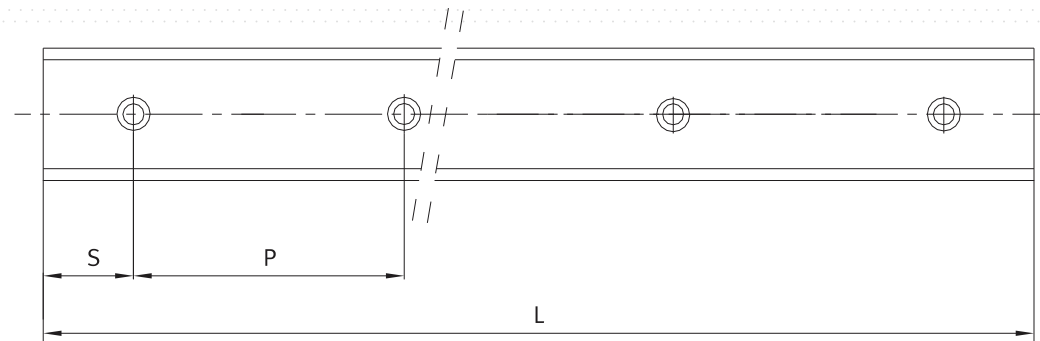

Spacer Railway

Type	A		B		C	
	P1	P3	P1	P3	P1	P3
SB-LGV25XL	25	25.2	12.25	12.9	15	15.5
SB-LGV44XL	44	44.2	15.5	16.2	26	26.5
SB-LGV76XL	76	76.2	24	24.7	50	50.5

Bearing

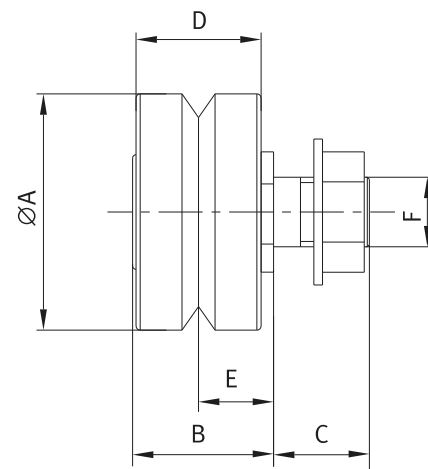

Type	Dimensions									
	A	B	C	D	E	F	G	H	I	J
SVR-25C SVR-25E	25	16.4	11.3	14	9	M8	8	13	3	- 0.75
SVR-34C SVR-34E	34	21	14.3	18	1.5	M10	10	15	4	- 1
SVR-54C SVR-54E	54	33.5	19.8	28	19	M14	14	27	6	- 1.5

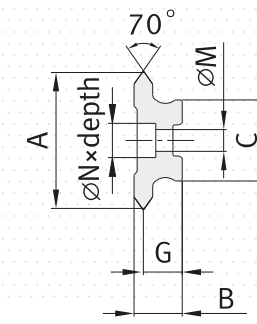

P1

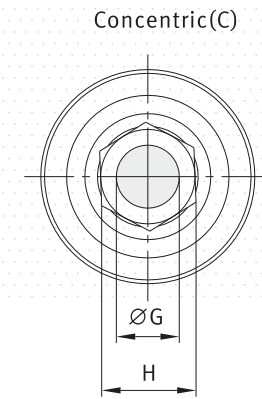

Concentric(C)

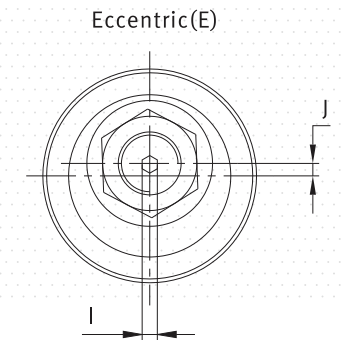

Eccentric(E)

G						Lmax	
P1	P3	M	NxD	P	S	P1	P3
10	10.35	5.5	10x5.5	90	45	1400	5500
12.5	12.85	7	11x7	90	45	2000	5500
19.5	19.85	11	20x12	90	45	1900	5500

Max working load capacities(N)				Bearing Static (Co) and Dynamic (C) Load Capacities (N)							
Double Row Bearings		Twin Bearings		For Double Row Bearings				For each of two Twin Bearings			
Radial	Axial	Radial	Axial	Radial loads		Axial loads		Radial loads		Axial loads	
				Co	C	Co	C	Co	C	Co	C
1500	400	600	320	2646	5214	821	1618	1333	3237	326	791
3000	900	1400	800	5018	9293	1362	2553	2600	5291	557	1270
5000	2500	3200	1800	12899	21373	2777	4601	6657	13595	1136	2320

Standard Carriage Dimension

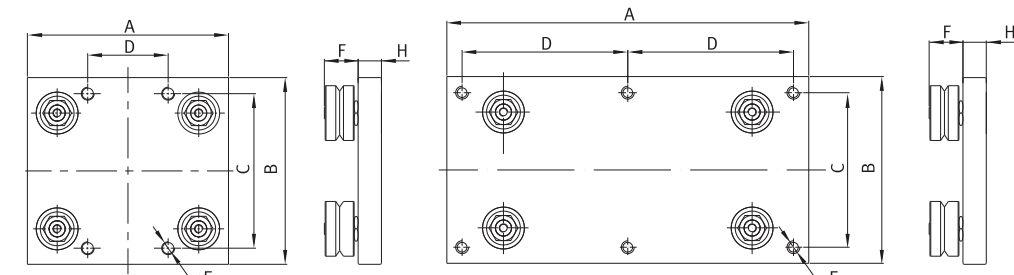

SB-SCP A

SB-SCP B/C

Type	Applicable Railway	Applicable Bearing	Max working load capacities(N)										
			A	B	C	D	E	F	H	Double Row Bearings		Twin Bearings	
										Fy	Fz	Fy	Fz
SLC25A SLC25B SLC25C	LGV25XL	SVR-25C SVR-25E	80 135 180	80	65	24 60 82	4xM6 6xM6 6xM6	16.5	11.5	1600	3000	1280	1200
SLC44A SLC44B SLC44C	LGV44XL	SVR-34C SVR-34E	125 180 225	116	96	50 80 103	4xM8 6xM8 6xM8	21	14.5	3600	6000	3200	2800
SLC76A SLC76B SLC76C	LGV76XL	SVR-54C SVR-54E	200 300 400	185	160	90 135 185	4xM10 6xM10 6xM10	33.5	20	10000	10000	7200	6400

The specifications and data in this publication are believed to be accurate and reliable. However, it is the responsibility of the product user to determine the suitability of Helix products for a specific application. While defective products will be replaced without charge if promptly returned, no liability is assumed beyond such replacement.



RING MOTION COMPONENTS

Construction

Please see below figure. This system includes Double edge V RingRail, Concentric Bearing, Eccentric Bearing, Carriage block, Lubricator. Gear teeth can be cut in the rail's space inside or outside of the rings to make drive compact and easy. Rail, bearing and other components are designed interchangeable with all of international standard suppliers.

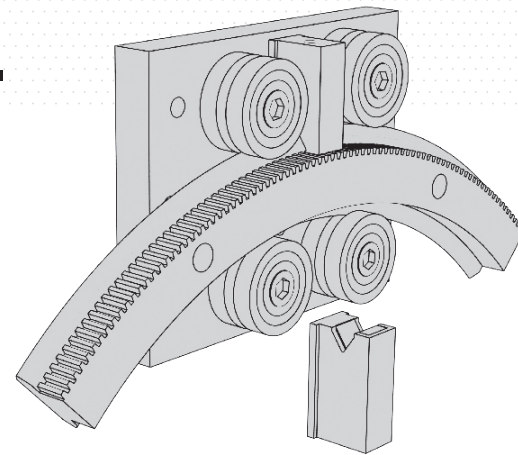

Double V-Edge Ring Rail

- Made of high quality bearing steel
- Deep hardened in working surfaces for high wear resistance
- Ground Double 70° V working edges ensure parallelism
- All surfaces are ground for precision
- Provide wide range of standard sizes for customer's selection
- Customized assembly holes are available

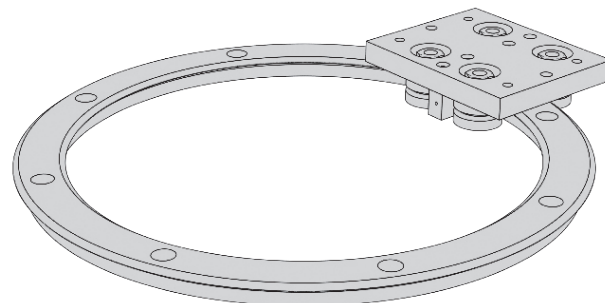

Gear Integrated Double V-Edge Ring Rail

- Made of high quality bearing steel
- Deep hardened in working surfaces for high wear resistance
- Ground Double 70° V working edges ensure parallelism
- All surfaces are ground for precision
- Provide wide range of standard sizes for customer's selection
- Gear teeth are available inside or outside of the ring rail's spacer
- Customized assembly holes are available

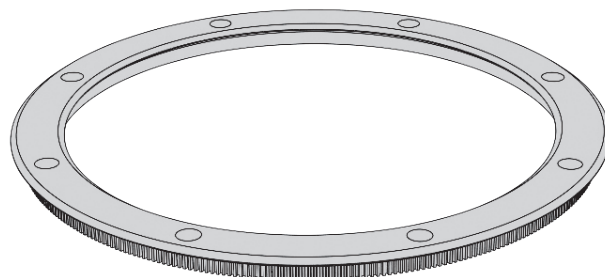

Single V-Edge Ring Rail

- Made of high quality bearing steel
- Deep hardened in working surfaces for high wear resistance
- Ground 70° V working edges
- All surfaces are ground for precision
- Provide wide range of standard sizes for customer's selection
- Gear teeth are available inside or outside of the ring rail's spacer
- Customized assembly holes are available

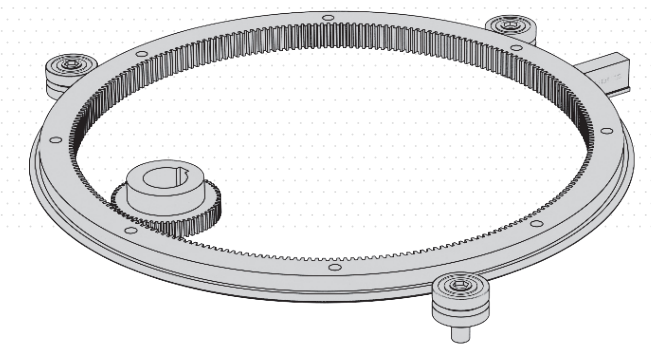

V Ring Rail Segment

- All above mentioned ring rails could be cut to segment
- Segment length could be customized
- Double Edge ring rail Segment could be connected to Linear Double Edge Rail to make circle motion system

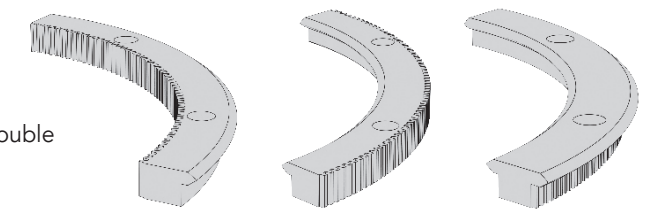

Concentric / Eccentric Bearing

- Made of high quality bearing steel
- Whole body hardened for high wear resistance
- Supply Twin type and Double row type bearings (See figure)
- Long bolt for thick carriage block
- Short bolt for thin carriage block
- Concentric / Eccentric bolt supplied

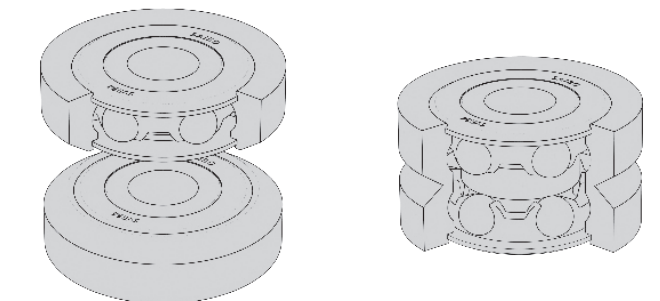

□ Twin Type Bearing

■ Double Row Type Bearing

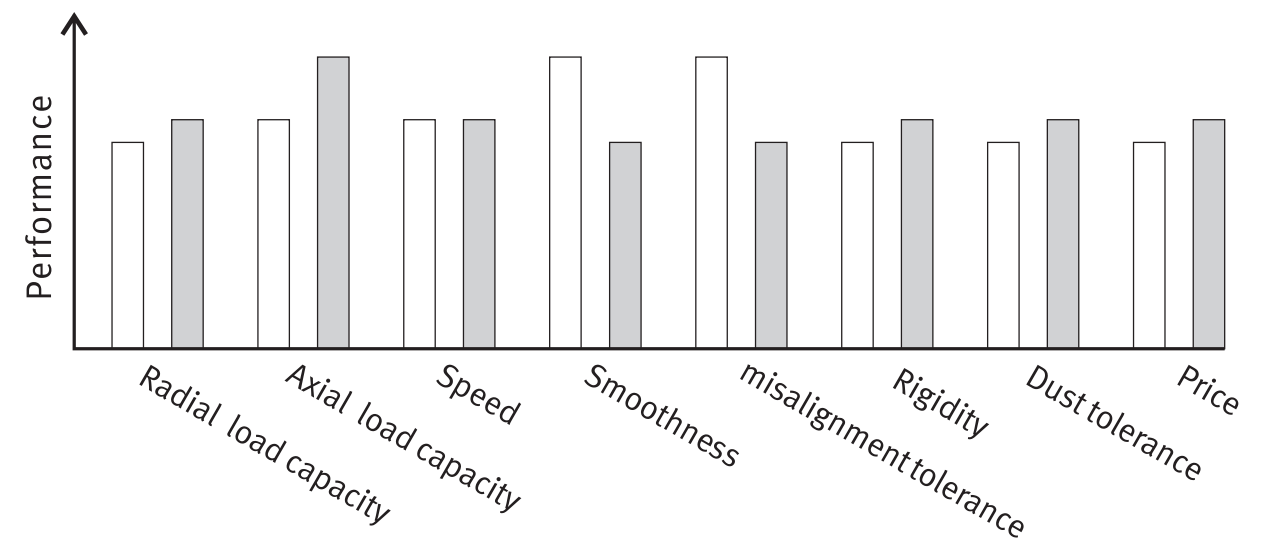

The specifications and data in this publication are believed to be accurate and reliable. However, it is the responsibility of the product user to determine the suitability of Helix products for a specific application. While defective products will be replaced without charge if promptly returned, no liability is assumed beyond such replacement.



Floating Bearing

- Outer ring could float in axial direction for tolerance of height
- Made of high quality bearing steel
- Whole body hardened for high wear resistance
- Long bolt for thick carriage block
- Short bolt for thin carriage block
- Concentric / Eccentric bolt supplied

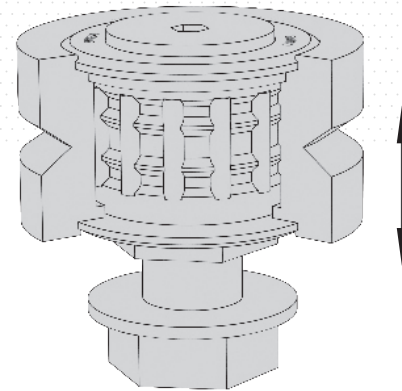

Lubricate

- Lubricated felt wiper contact rail's working surface to increase load capacity and life
- Lubricated felt wiper is pushed lightly by a small spring to ensure low friction with the rail's working surface
- Oil charging holes supplied for the Track Motion System
- Automatic lubricate bleed could connect to the rail's oil charging holes very easily.
- Standard and interchangeable

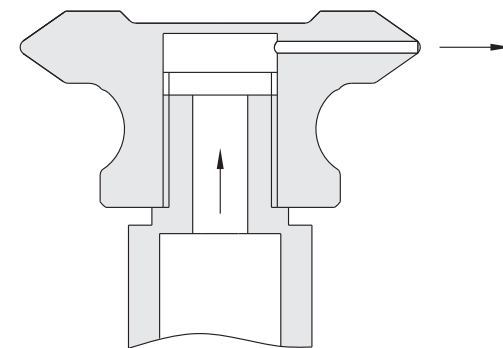
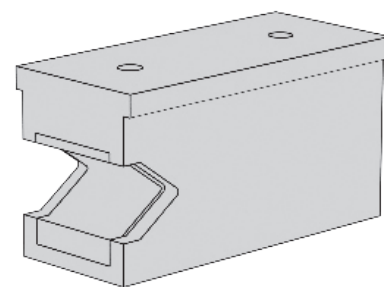
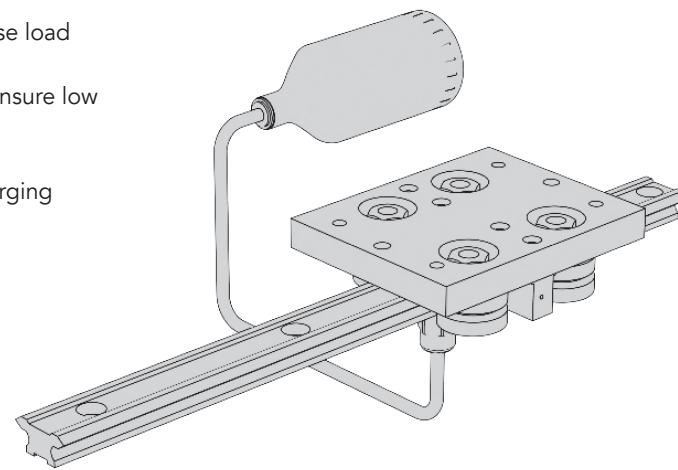

APPLICATION EXAMPLES

Track Motion System with Belt Driven

- Whole assembled complete machine are available
- Whole drive components are available
- Position and locking system integrated
- Automatic lubricate system integrated
- High-load and high-precision angular contact bearings used in driven shaft.
- Zero axial play for all driven shafts

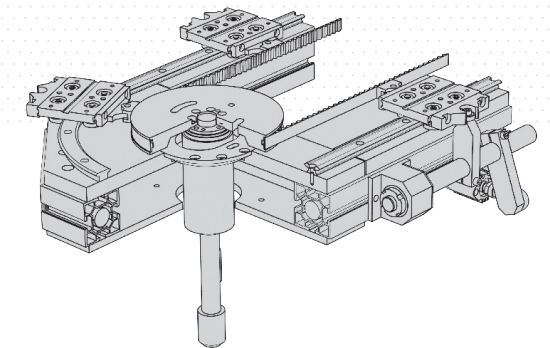

Rectangle Circle System with Chain Driven

- Whole assembled complete machine are available
- Whole drive components are available
- Torque Limiter to protect overload
- Any length available for linear rails in two directions
- Carriage could be add or remove very conveniently

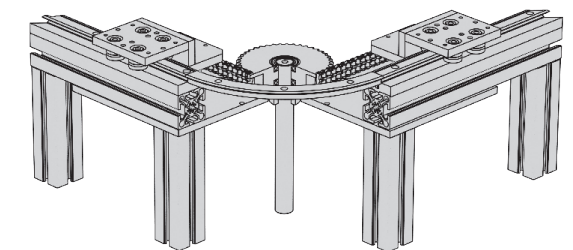

Track Motion System Mounted in Parallel

- Whole assembled complete machine are available
- Whole drive components are available
- Floating bearing used in one side to tolerant axial play
- Fit for long size component and tooling
- Heavy duty teeth belt driven enable motion smooth and quiet

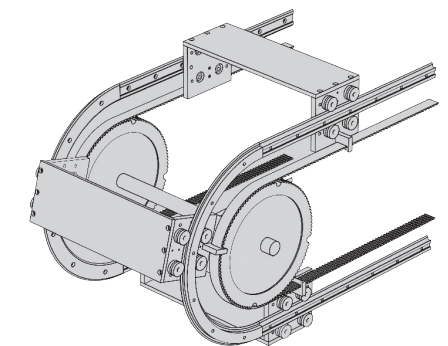

S Bend Track

- Bogie frame applied to S bend track and different radii
- Heavy load capacity up to 1000Kg
- Large platform design for big size mounting
- Bogie rotates smooth
- Available for rail size 25, 44, 76
- Customized track design
- Driven equipment could be supplied according to specific bend track

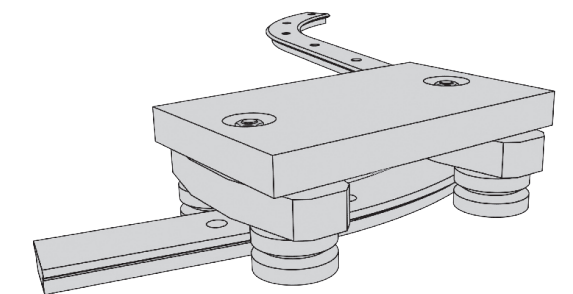

The specifications and data in this publication are believed to be accurate and reliable. However, it is the responsibility of the product user to determine the suitability of Helix products for a specific application. While defective products will be replaced without charge if promptly returned, no liability is assumed beyond such replacement.



FULL SIZE OVERVIEW

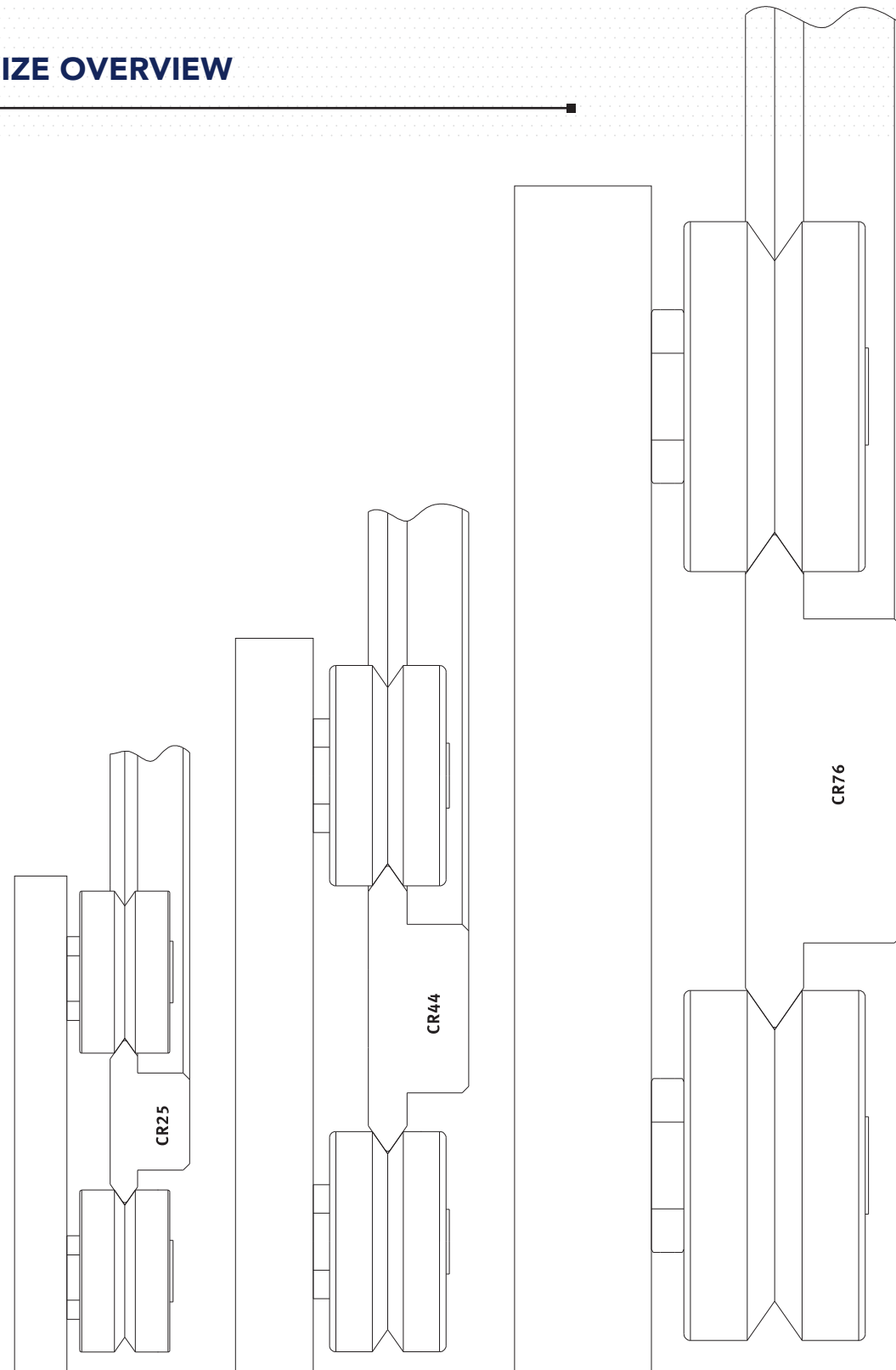

OVAL TRACK SYSTEM

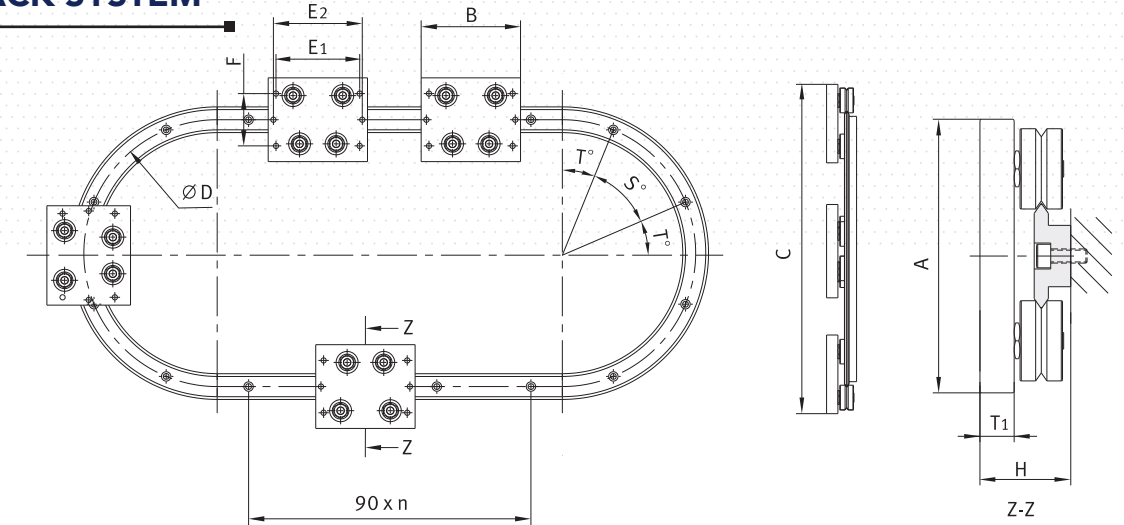

Assembly Type	Components		
	Linear Railway	Ring Railway	Carriage
SB-LGV25XL-CR25 159 R180 SB-LGV25XL-CR25 255 R180 SB-LGV25XL-CR25 351 R180	SB-LGV25	SB-CR25 159 R180 SB-CR25 255 R180 SB-CR25 351 R180	SB-SRC25 159 SB-SRC25 255 SB-SRC25 351
SB-LGV44XL-CR44 468 R180 SB-LGV44XL-CR44 612 R180	SB-LGV44	SB-CR44 468 R180 SB-CR44 612 R180	SB-SRC44 468 SB-SRC44 612
SB-LGV76XL-CR76 799 R180 SB-LGV76XL-CR76 1033 R180 SB-LGV76XL-CR76 1267 R180 SB-LGV76XL-CR76 1501 R180	SB-LGV76	SB-CR76 799 R180 SB-CR76 1033 R180 SB-CR 1267 R180 SB-CR 1501 R180	SB-SRC76 799 SB-SRC76 1033 SB-SRC76 1267 SB-SRC76 1501

TYPE CODE DETAILS

SB- LGV 25 X2000 -CR25 159 R180

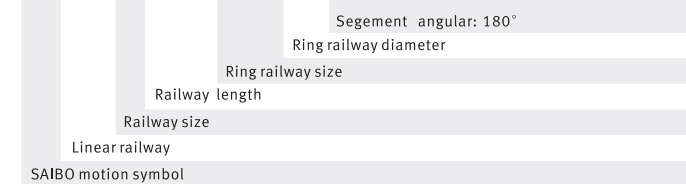

Dimension										
A	B	C	D	E1	E2	F	H	T1	S°	T°
80	95	239	159	85	80	50	30.5	11.5	45	22.5
	100	335	255	80	85				45	22.5
	105	431	351	85	90				30	15
116	145	584	468	120	125	75	38.5	14.5	30	15
	150	728	612	125	130				22.5	11.25
185	190	984	799	160	165	100	58.5	20	22.5	11.25
	210	1218	1033	180	185				18	9
	250	1452	1267	205	225				18	9
	270	1686	1501	225	245				18	9

The specifications and data in this publication are believed to be accurate and reliable. However, it is the responsibility of the product user to determine the suitability of Helix products for a specific application. While defective products will be replaced without charge if promptly returned, no liability is assumed beyond such replacement.



RING RAIL

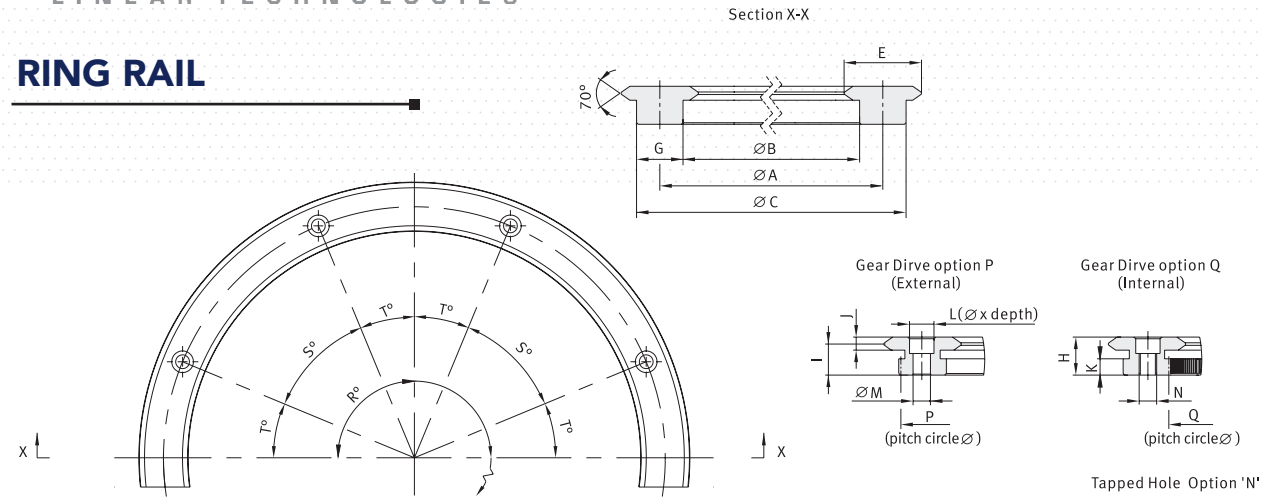

Type	Applicable Bearing	A	B	C	E	G	H	I	J	K	(xdepth)
CR25 159	SVR-25	159	143.6	174.4	25	15	12.25	10	4.2	5.25	9x6
CR25 255	SVR-25	255	239.6	270.4	25	15	12.25	10	4.2	5.25	9x6
CR25 351	SVR-25	351	335.6	366.4	25	15	12.25	10	4.2	5.25	9x6
CR44 468	SVR-34	468	442	494	44	26	15.5	12.5	6	7	11x7
CR44 612	SVR-34	612	586	638	44	26	15.5	12.5	6	7	11x7
CR76 799	SVR-54	799	748.5	849.5	76	50	24	19.5	9	12	20x13
CR76 1033	SVR-54	1033	982.5	1083.5	76	50	24	19.5	9	12	20x13
CR76 1267	SVR-54	1267	1216.5	1317.5	76	50	24	19.5	9	12	20x13
CR76 1501	SVR-54	1501	1450.5	1551.5	76	50	24	19.5	9	12	20x13

TYPE CODE DETAILS

CR25 351 R180 (P) (Q) (N)

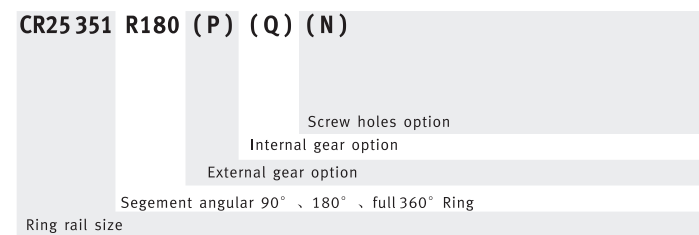

M	N	External Gear		Internal Gear		Holes' Position ±0.2		Weight (kg) (R=360°)			
		P	m	Q	m	S°	T°				
5.5	M8	172.8	0.8	216	145.6	0.8	182	8	45	22.5	0.77
5.5	M8	268.8	0.8	336	241.6	0.8	302	8	45	22.5	1.2
5.5	M8	364.8	0.8	456	337.6	0.8	422	12	30	15	1.65
7	M8	492	1	492	444	1	444	12	30	15	5.1
7	M8	636	1	636	588	1	588	16	22.5	11.25	6.7
11	M16	846	1.5	564	751.5	1.5	501	16	22.5	11.25	25
11	M16	1080	1.5	720	985.5	1.5	657	20	18	9	32
11	M16	1314	1.5	876	1219.5	1.5	813	20	18	9	41
11	M16	1548	1.5	1032	1453.5	1.5	969	20	18	9	48.7

RING RAIL

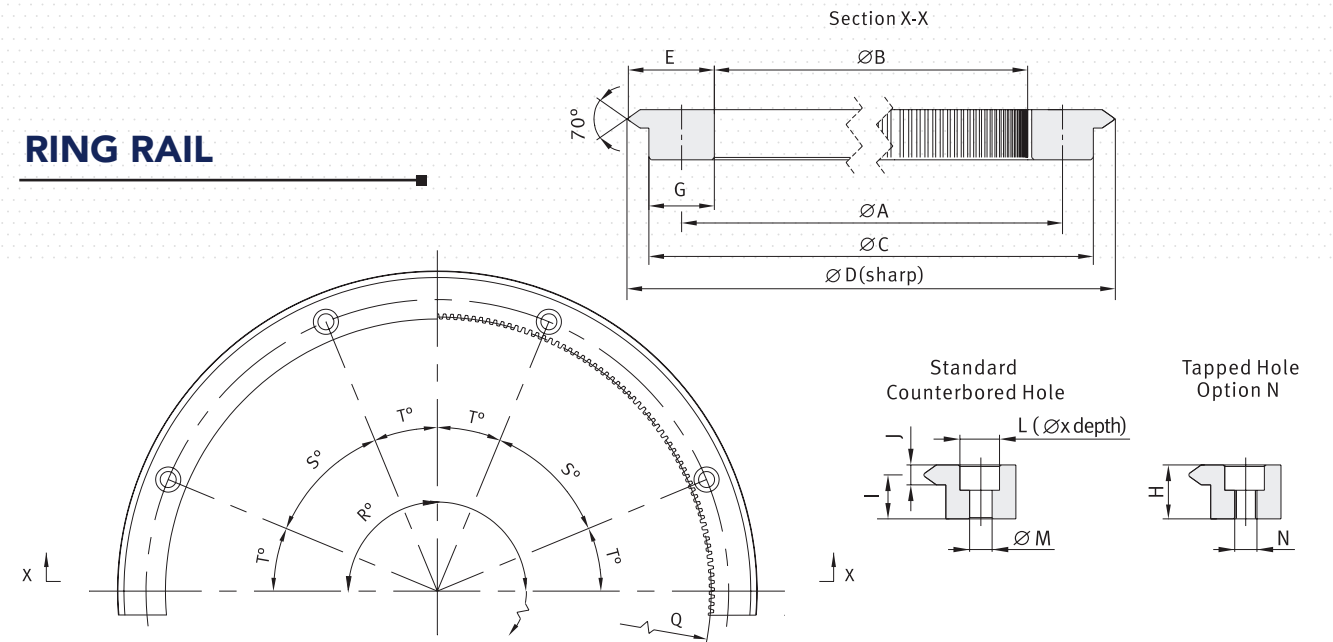

Type	Applicable Bearing	A	B	C	D	E	G	H	I
CES 184	SVR-25	159	142	174	184.74	20.8	16	12.25	10
CES 280	SVR-25	255	238	270	280.74	20.8	16	12.25	10
CES 376	SVR-25	351	334	366	376.74	20.8	16	12.25	10
CEM 505	SVR-34	468.5	447.5	487.5	506.24	28.8	20	15.5	12.5
CEM 655	SVR-34	618.5	597.5	637.5	656.24	28.8	20	15.5	12.5
CEM 874	SVR-54	820	788	848	874.74	42.8	30	24	19.5

TYPE CODE DETAILS

CES376 R180 (Q) (N)

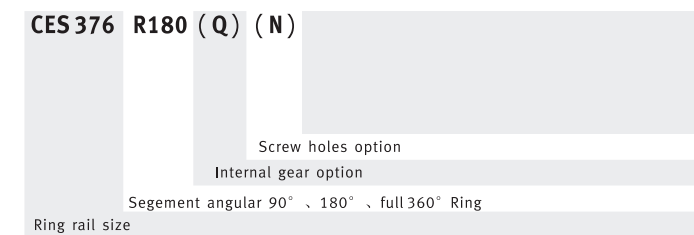

J	L (xdepth)	M	N	Internal Gear		Hole number (R=360°)	Holes' Position ±0.2		Weight (kg) (R=360°)	
				Q	m		S°	T°		
4.5	10x5.5	5.5	M8	144	1	144	8	45	22.5	0.78
4.5	10x5.5	5.5	M8	240	1	240	8	45	22.5	1.27
4.5	10x5.5	5.5	M8	336	1	336	12	30	15	1.75
6	11x6.5	7	M8	450	1.25	360	12	30	15	3.93
6	11x6.5	7	M8	600	1.25	480	16	22.5	11.25	5.18
9	18x10.5	11	M16	792	2	396	16	22.5	11.25	15.64

The specifications and data in this publication are believed to be accurate and reliable. However, it is the responsibility of the product user to determine the suitability of Helix products for a specific application. While defective products will be replaced without charge if promptly returned, no liability is assumed beyond such replacement.



RING RAIL

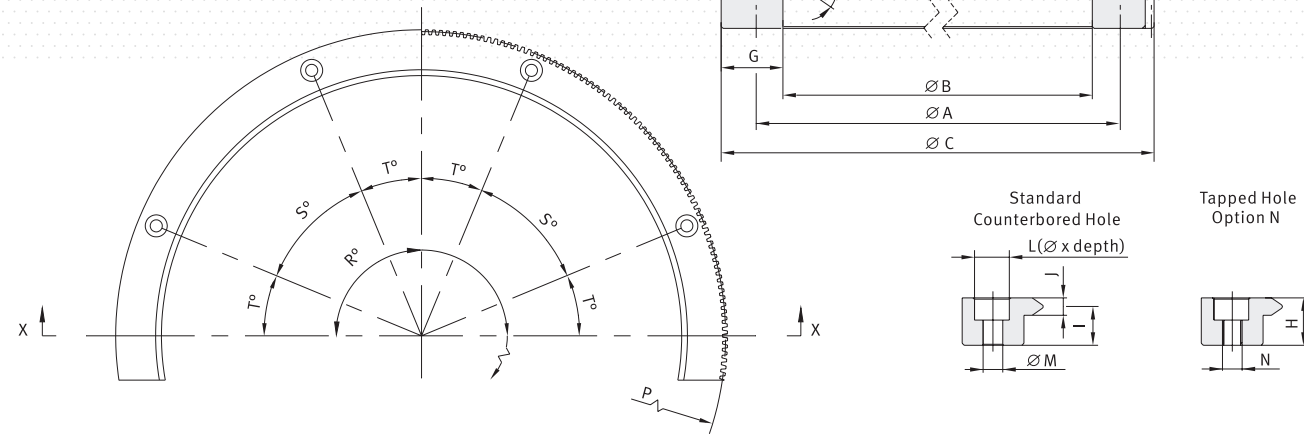

Type	Applicable Bearing	A	B	C	D	E	G	H	I
CIS 182	SVR-25	165	150	182	139.26	20.8	16	12.25	10
CIS 278	SVR-25	261	246	278	235.26	20.8	16	12.25	10
CIS 374	SVR-25	357	342	374	331.26	20.8	16	12.25	10
CIM 482	SVR-34	461.5	442.5	482.5	423.76	28.8	20	15.5	12.5
CIM 627	SVR-34	606.5	587.5	627.5	568.76	28.8	20	15.5	12.5
CIL 820	SVR-54	788	760	820	733.26	42.8	30	24	19.5

TYPE CODE DETAILS

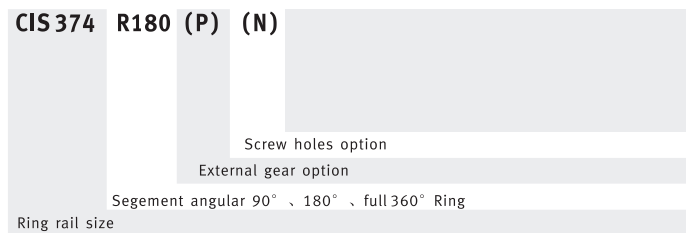

J	L	M	N	External Gear		Teeth Qty (R=360°)	Hole number (R=360°)	Holes' Position ±0.2		Weight (kg) (R=360°)
				P	m			S°	T°	
4.5	10x5.5	5.5	M8	180	1	180	8	45	22.5	0.78
4.5	10x5.5	5.5	M8	276	1	276	8	45	22.5	1.27
4.5	10x5.5	5.5	M8	372	1	372	12	30	15	1.75
6	11x6.5	6.8	M8	480	1.25	384	12	30	15	3.93
6	11x6.5	6.8	M8	625	1.25	500	16	22.5	11.25	5.18
9	18x10.5	11	M16	816	2	408	16	22.5	11.25	15.64

CONCENTRIC / ECCENTRIC BEARING DIMENSION

Type	Dimension									
	A	B	C	D	E	F	G	H	I	J
SVR-25C SVR-25DE	25	16.5	11.3	14	9	M8	8	13	3	-2
SVR-34C SVR-34DE	34	21	14.3	18	11.5	M10	10	15	4	-2.5
SVR-54C SVR-54DE	54	33.5	19.8	28	19	M14	14	27	6	-5.5

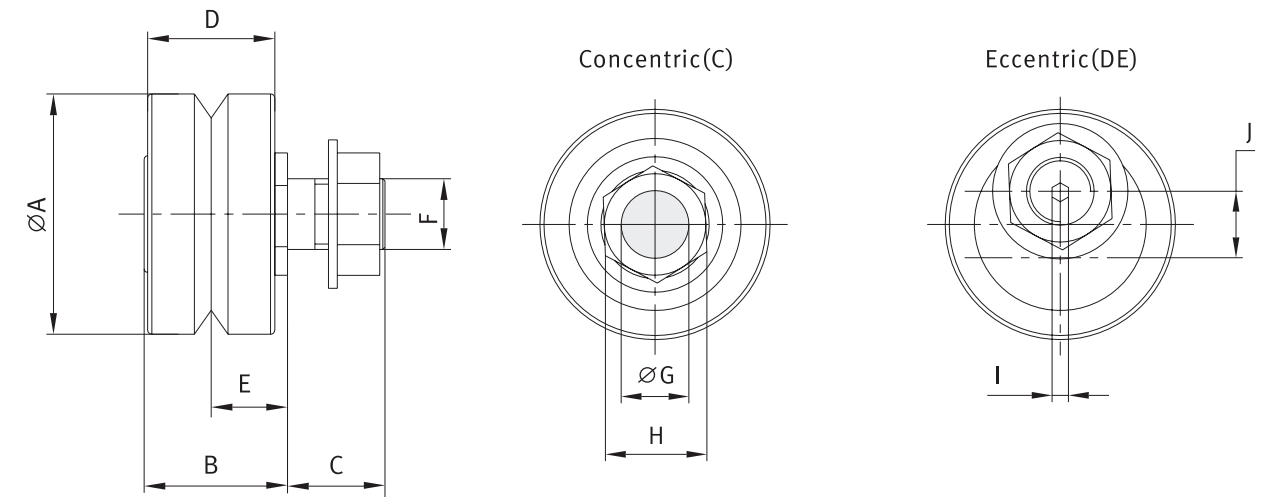

Max working load capacities(N)				Bearing Static(Co)and Dynamic(C) Load Capacities(N)							
Double Row Bearings		Twin Bearings		For Double Row Bearings				For each of two Twin Bearings			
				Radial loads		Axial Loads		Radial loads		Axial Loads	
Radial	Axial	Radial	Axial	Co	C	Co	C	Co	C	Co	C
1500	400	600	320	2646	5214	821	1618	1333	3237	326	791
3000	900	1400	800	5018	9293	1362	2523	2600	5291	557	1270
5000	2500	3200	1800	12899	21373	2777	4601	6657	13595	1136	2320

The specifications and data in this publication are believed to be accurate and reliable. However, it is the responsibility of the product user to determine the suitability of Helix products for a specific application. While defective products will be replaced without charge if promptly returned, no liability is assumed beyond such replacement.



CONCENTRIC / ECCENTRIC BEARING DIMENSION

Type	Dimension					
	A	B	C	D	E	
					Max	Min
FSVR-25C FSVR-25E	25	18.1	11.3	14	10.5	9
FSVR-34C FSVR-34E	34	23.2	14.3	18	13.5	11.5
FSVR-54C FSVR-54E	54	37.2	19.8	28	21.6	19

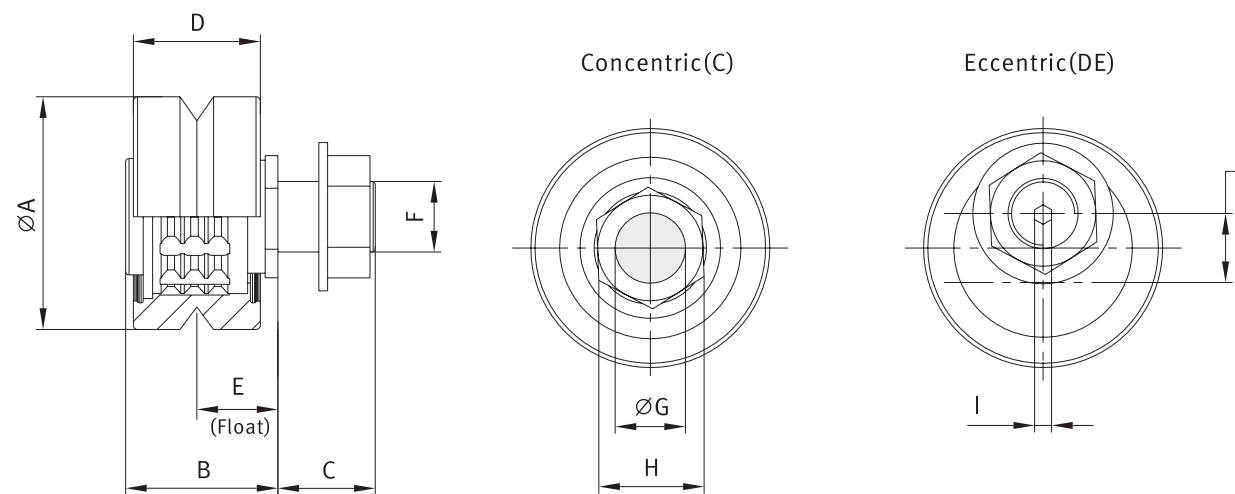

F	G	H	I	J	Bearing Static(Co)and Dynamic(C)Load Capacities(N)		Max working load capacities(N)
					Co	C	
M8	8	13	3	- 2	6100	4900	1500
M10	10	15	4	- 2.5	12500	11500	3000
M14	14	27	6	- 5.5	28900	21500	5000

STANDARD CARRIAGE DIMENSION

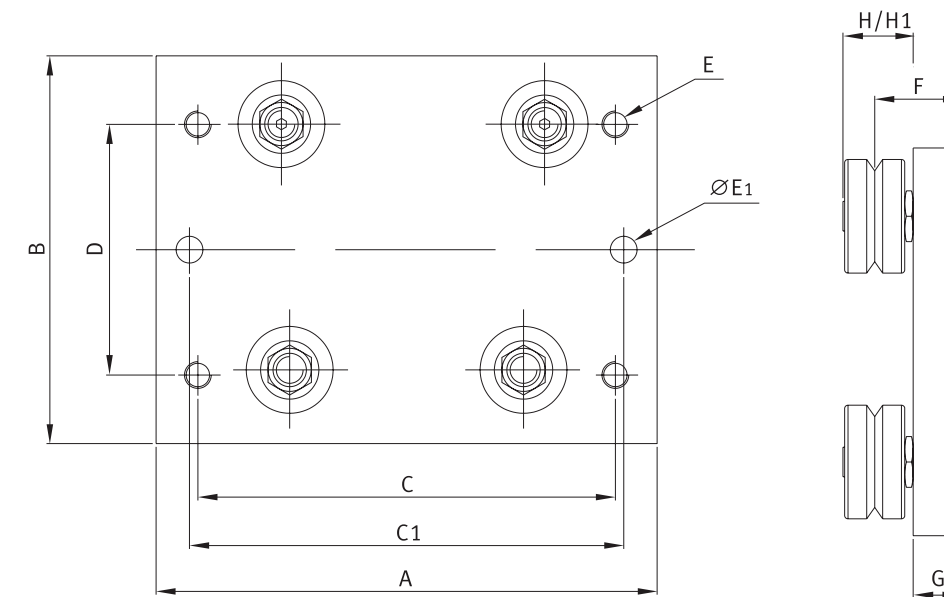

Type	A	B	C	C1	D	E	E1	F	G	H	H1	Weight (kg)
SRC25 159	95	80	85	80	50	4×M6	2×6	20.5	11.5	16.6	18.1	0.4
SRC25 255	100	80	80	85	50	4×M6	2×6	20.5	11.5	16.6	18.1	0.41
SRC25 351	105	80	85	90	50	4×M6	2×6	20.5	11.5	16.6	18.1	0.42
SRC44 468	145	116	120	125	75	4×M8	2×8	26	14.5	21.3	23.2	1.08
SRC44 612	150	116	125	130	75	4×M8	2×8	26	14.5	21.3	23.2	1.1
SRC76 799	190	185	160	165	100	4×M10	2×10	39	20	34.7	37.2	3.46
SRC76 1033	210	185	180	185	100	4×M10	2×10	39	20	34.7	37.2	3.66
SRC76 1267	250	185	205	225	100	4×M10	2×10	39	20	34.7	37.2	4.05
SRC76 1501	270	185	225	245	100	4×M10	2×10	39	20	34.7	37.2	4.25

The specifications and data in this publication are believed to be accurate and reliable. However, it is the responsibility of the product user to determine the suitability of Helix products for a specific application. While defective products will be replaced without charge if promptly returned, no liability is assumed beyond such replacement.



ASSEMBLY MENU

1. V track bearing match carriage plate

Please mount the concentric bearing to one side of carriage plate, and eccentric bearing to the other side following the direction of railway. In case of ring type carriage, the concentric bearing should be mounted to the side where mounting-hole distance is shorter. Please refer to below picture.

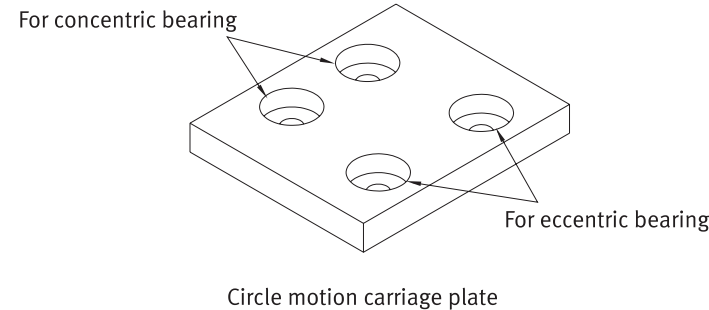

2. Mounting to railway

Carriage assembly should be mounted from the end of railway. Please do not put any overstress when mounting.

3. Adjust the clearance between bearing and railway

- Tighten concentric bearings first.
- Then rotate eccentric bearing via rotate hexagonal key at the end of stud to adjust the clearance between railway and bearing.
- Adjust the clearance to zero.
- Slide the carriage by hand and adjust to the extent where there causes a slight slipping resistance.
- Correct condition is where moving power becomes the recommended value as below table by putting load by push-pull gauge to the running direction of carriage.

Recommended pre-load by push-pull gauge

V track bearing size	Pre-load(N)
25	4
44	8
76	12

-Keep eccentric bearing's position and tighten the nut.

Important Note

Appropriate pre-load provide the system rigidity. However, over preload will decrease system's life rapidly. Please be careful.

Load / Life calculation

Due to the hardness of the railway and fatigue analysis of railway and roller, the railway's life does not determine the system life. It is determined by roller's life. Load capacity of the motion guide system varies mainly by the size of bearing and railway, lubricated or not, and the load magnitude and direction. Other factors include speed and acceleration and environment etc. To calculate system life, loading factor LF should be calculated firstly. Here we provide two methods to calculate the loading factor.

Standard 4 bearings carriage calculation

If the system use Helix standard 4 bearings carriage, then calculation can use below formula.

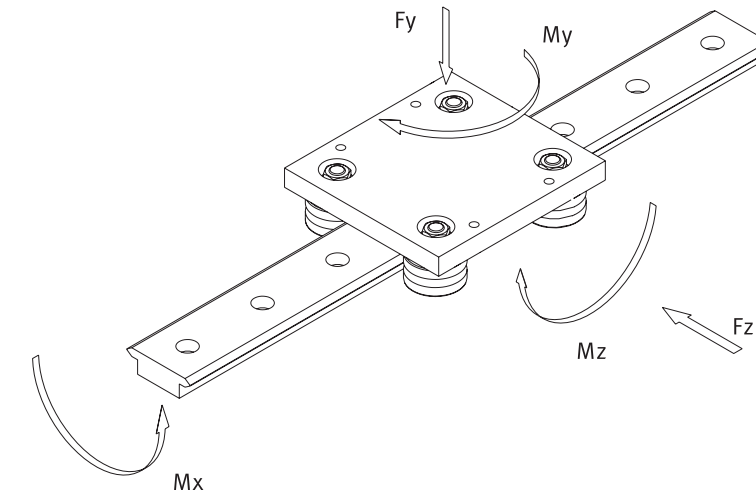

$$LF = \frac{Fy}{Fy_{max}} + \frac{Fz}{Fz_{max}} + \frac{Mx}{Mx_{max}} + \frac{My}{My_{max}} + \frac{Mz}{Mz_{max}}$$

Fy - Actual load in Y direction. (N)

Fy - Actual load in Y direction. (N)

Fz - Actual load in Z direction. (N)

Mx - Actual moment in X direction. (N.m)

My - Actual moment in Y direction. (N.m)

Mz - Actual moment in Z direction. (N.m)

Below parameters can be taken from the table of Load capacity.

Fy max - Max load capacity in Y direction. (N)

Fz max - Max load capacity in Z direction. (N)

Mx max - Max moment capacity in X direction. (N.m)

My max - Max moment capacity in Y direction. (N.m)

Mz max - Max moment capacity in Z direction. (N.m)

The specifications and data in this publication are believed to be accurate and reliable. However, it is the responsibility of the product user to determine the suitability of Helix products for a specific application. While defective products will be replaced without charge if promptly returned, no liability is assumed beyond such replacement.



MAXIMUM LOAD CAPACITY

Linear railway's carriage

Carriage Type	Dry system Double Row Bearings and Twin Bearings					Lubricated system/Twin Bearings					Lubricated system/Double Row Bearings				
	Fy	Fz	Mx	My	Mz	Fy	Fz	Mx	My	Mz	Fy	Fz	Mx	My	Mz
	N	N	Nm	Nm	Nm	N	N	Nm	Nm	Nm	N	N	Nm	Nm	Nm
SLC25	400	400	4.5	200xD	200xD	1280	1200	14	600xD	640xD	1600	3000	18	1500xD	800xD
SLC44	800	800	16	400xD	400xD	3200	2800	65	1400xD	1600xD	3600	6000	73	3000xD	1800xD
SLC76	1800	1800	64	900xD	900xD	7200	6400	250	3200xD	3600xD	10000	10000	360	5000xD	5000xD

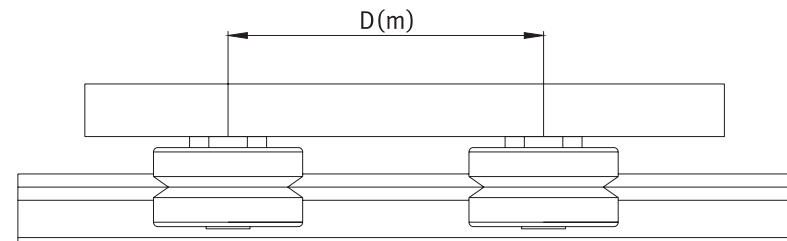

Ring railway's carriage

Carriage Type	Dry system Double Row Bearings and Twin Bearings					Lubricated system/Twin Bearings					Lubricated system/Double Row Bearings				
	Fy	Fz	Mx	My	Mz	Fy	Fz	Mx	My	Mz	Fy	Fz	Mx	My	Mz
	N	N	Nm	Nm	Nm	N	N	Nm	Nm	Nm	N	N	Nm	Nm	Nm
SRC25 159	400	400	4.5	8.5	8.5	1280	1200	14	25	27	1600	3000	18	64	33
SRC25 255	400	400	4.5	8	8	1280	1200	14	23	25	1600	3000	18	60	31
SRC25 351	400	400	4.5	8.5	8.5	1280	1200	14	24	27	1600	3000	18	63	33
SRC44 468	800	800	16	28	28	3200	2800	64	95	110	3600	6000	73	210	120
SRC44 612	800	800	16	29	29	3200	2800	64	100	115	3600	6000	73	220	130
SRC76 799	1800	1800	64	85	85	7200	6400	250	300	340	10000	10000	360	470	470
SRC76 1033	1800	1800	64	105	105	7200	6400	250	360	410	10000	10000	360	570	570
SRC76 1267	1800	1800	64	120	120	7200	6400	250	420	480	10000	10000	360	670	670
SRC76 1501	1800	1800	64	140	140	7200	6400	250	480	550	10000	10000	360	770	770

Individual V track bearing calculation

If the system does not use Helix standard 4 bearing carriage, It is necessary to calculate each bearing's loading factor. Biggest loaded bearing's load determines the system's life.

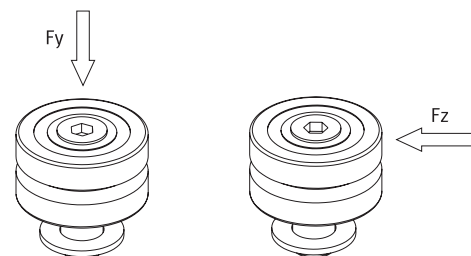

$$LF = \frac{Fy}{Fy_{max}} + \frac{Fz}{Fz_{max}}$$

LF - Loading factor
 LF should be less than 1.0 for any combination of load
 Fy - Actual axial capacity. (N)
 Fz - Actual radial capacity. (N)

Below parameters can be taken from below table.
 Fy max - Max axial load. (N)
 Fz max - Max radial load. (N)

Bearing's load capacity

Bearing type	Double Row Bearings				Each of Two Twin Bearings			
	Radial loads		Axial Loads		Radial loads		Axial Loads	
	Co	C	Co	C	Co	C	Co	C
SVR-25C SVR-25E	2646	5214	821	1618	1333	3237	326	791
SVR-34C SVR-34E	5018	9293	1362	2523	2600	5291	557	1270
SVR-54C SVR-54E	12899	21373	2777	4601	6657	13595	1136	2320

Life calculation

After getting Loading Factor LF, the life in km can be calculated by selecting one of below two formulas. The basic life can be taken from table below.

Dry System

$$Life(km) = \frac{Basic_life}{(0.03+0.97LF*f)^2}$$

Lubricated System

$$Life(km) = \frac{Basic_life}{(0.03+0.97LF*f)^3}$$

The specifications and data in this publication are believed to be accurate and reliable. However, it is the responsibility of the product user to determine the suitability of Helix products for a specific application. While defective products will be replaced without charge if promptly returned, no liability is assumed beyond such replacement.



Basic Life

Bearing Type	Dry System	Lubricated System
SVR-25	100	150
SVR-34	100	150
SVR-54	150	250

f - Reduction coefficient of the application and environment.

None vibration or shock, Low speed (< 1m/s), Low frequency shift direction, clean environment.	1 - 1.5
Light vibration or shock, medium speed (1-2.5m/s) medium frequency shift direction, some dirtiness	1.5 - 2
Heavy vibration or shock, high speed (> 2.5m/s) high frequency shift direction, heavy dirty	2 - 3.5

Calculation Example

A machine use SB-LGV25 spacer railway and standard carriage. The carriage and work-piece total weight 8 kg. When the carriage moving, there is an external load of 50 N exerted as below drawing. Working environment is clean. There is none vibration or shock.

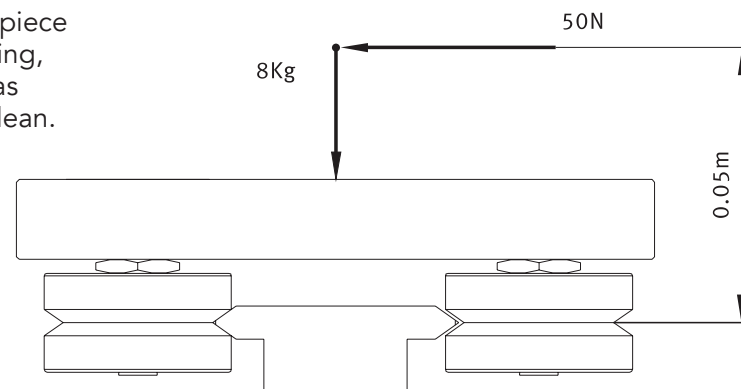

The load factor LF is calculated use formula

$$LF = \frac{F_y}{F_{y\max}} + \frac{F_z}{F_{z\max}} + \frac{M_x}{M_{x\max}} + \frac{M_y}{M_{y\max}} + \frac{M_z}{M_{z\max}}$$

$$F_y = 8\text{kg} \times 9.8 \text{ (gravity)} = 78.40 \text{ N}$$

$$F_z = 50 \text{ N}$$

$$M_x = 50 \times 0.05 = 2.5 \text{ N}\cdot\text{m}$$

$$M_y = 0$$

$$M_z = 0$$

Take parameters $F_y \max$, $F_z \max$, $M_x \max$, $M_y \max$, $M_z \max$ from table and then fill in the formula

$$LF = \frac{78.4}{1280} + \frac{50}{1200} + \frac{2.5}{14} + \frac{0}{M_{y\max}} + \frac{0}{M_{z\max}} = 0.2816$$

Then life (km) calculation can use formula as below:

$$\text{Life(km)} = \frac{\text{Basic_life}}{(0.03+0.97LF*f)^2}$$

Basic life is 100km.

According to the description of working condition, take $f=1.3$.

$$\text{Life(km)} = \frac{100}{(0.03+0.97*0.2816*1.3)^2} = 674\text{km}$$

Basic life is 150 km, take $f=1.1$

$$\text{Life(km)} = \frac{\text{Basic_life}}{(0.03+0.97LF*f)^3}$$

$$\text{Life(km)} = \frac{150}{(0.03+0.97*0.2816*1.1)^3} = 4155\text{km}$$

From this example, it shows clearly that lubrication is so important for the life. Please pay attention to install the lubrication system for your system.

Dry System

Lubricated System

All rights reserved. Due to constant development of the products,
we reserve the right of modifications without notifications.



HELIX LINEAR TECHNOLOGIES
23200 Commerce Park Road
Beachwood, OH 44122
1-855-HELIXLT or 216-485-2232

www.helixlinear.com
sales@helixlinear.com

