

Telescopic Linear Guide Rails



Partners



Certifications



ISO 9001:2015 with Design
Certificate No. 14.339.2



ITAR Registered

Table of Contents

About the Company	3
Product Overview	4
Product Specifications	5
Life Calculation	6
Partial Extension Rails.....	7-8
Full Extension Rails.....	9-10



Helix Linear Technologies, Inc., Beachwood, Ohio USA

Company

Helix Linear Technologies is a global manufacturer of linear actuators, lead screws and ball screws. Serving clients in the aerospace, medical, life science, security, semiconductor, and defense industries, we focus on helping our customers achieve their application and profitability goals. Our innovative product design and world-class engineering capabilities solve real-world linear motion issues, building a foundation for our client's long-term success.

Culture

Our culture is rooted in agility, responsiveness, and teamwork. Our team comprises happy, competitive professionals who are experts in manufacturing innovative electromechanical linear motion solutions. We strive to exceed our customers' expectations in all interactions and are committed to continuous improvement.

History

Helix Linear Technologies was founded in 2011 to meet the growing demand for high-precision lead screws in the electromechanical actuation industry. Our rapid growth and expanded product lines now include end-to-end linear actuator solutions, providing our clients with customized options and fully integrated solutions.

Market Segments Served

- | | | | |
|---|--|--|---|
|  Medical & Diagnostic |  Electronics |  Semiconductor |  Steel |
|  Aerospace |  Transportation |  Military and Defense |  Chemical |
|  Packaging |  Patient Handling |  Factory Automation |  Agriculture/Food Handling |
|  Automotive |  Entertainment |  Pulp & Paper |  Tire Manufacture |

Telescopic Linear Guide Rails

Overview

Helix Telescopic Linear Guide Rails are designed for heavy-duty industrial applications that require smooth telescopic sliding motion with no play. The external rail and internal slider are fabricated from cold-drawn steel with induction hardened ball races, providing heavy load capacity and excellent durability, making them the perfect solution in automation, packaging, automotive, and automated warehousing applications.

Helix Telescopic Linear Guide Rails are offered in two styles: partial extension (HTPE) and full extension (HTDB), to meet the needs of high-cycle, demanding applications. Custom configurations are also available, expanding the flexibility of your design options.

The structure of our telescopic rails is simple and compact, consisting of one C-shaped external rail, one internal slider, two rows of steel balls, and a ball cage. Limit Stoppers are affixed to preset extension ranges in the external and internal sliders. V-shaped concave raceways in the outer rail and inner slider allow the balls to run with four contact points. This contact structure achieves minimal displacement and acceleration forces. No additional clearance is added between raceways and balls to provide precision sliding and excellent rigidity.

Part Number Configuration Guide

HTPE28 - 210

Style	
HTPE	= partial extension rail
HTDB	= full extension rail

Size	
28	= 28mm height
43	= 43mm height

Length in Millimeters			
130	610	1090	1570
210	690	1170	1650
290	770	1250	1730
370	850	1330	1810
450	930	1410	1890
530	1010	1490	1970

Partial Extension Rails

The stroke of our partial extension rails reaches half (or more) of its length with exceptional rigidity and heavy load capacities.



Full Extension Rails

Our full extension telescopic rails consist of two partial extension rails affixed back to back, allowing the stroke to reach the entire length of the slider (or more) while providing excellent rigidity and load-carrying capabilities.

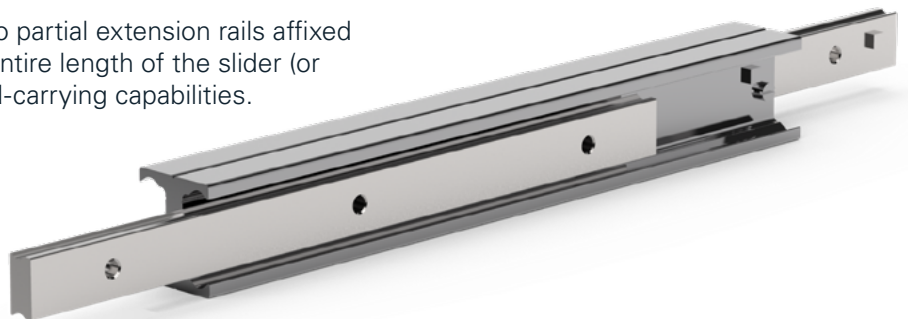

Bi-Directional Movement

If bi-directional movement is required, remove the screw stop at the edge of the rail.

Working Speed

The maximum recommended work speed for our telescopic linear guide rails is 0.8m/s. The overall rail length can influence work speed. Please refer to the maximum speed chart below.

Lubrication

High-quality lubrication will increase your telescopic linear guide rails's working life and reduce running noise. All telescopic linear guide rails are shipped with pre-lubricated raceways. Additional lubrication should be applied every 100 Km

Temperature

Our telescopic linear guide rails recommended operating temperature range is -20°C - 120° C, with a maximum operating temperature of 170 °C. However, function at temperatures higher than the recommended range should be limited to avoid reduced load capacity.

Load Capacity

Our telescopic linear guide rails are designed for heavy-load applications. Please reference detailed load parameters in the individual product tables for partial extension rails on pages 7 and 8 and full extension rails on pages 9 and 10. The maximum permissible loads shown in the product tables are calculated from the slider's center point at full extension.

When pairs of rails are mounted parallel and the load distribution is uniform, a drawer's max load (P) is two times the capacity of a single rail.

$$P=2(P1)$$

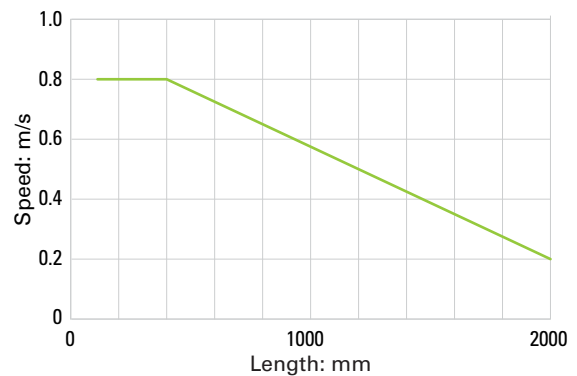

Working speed chart

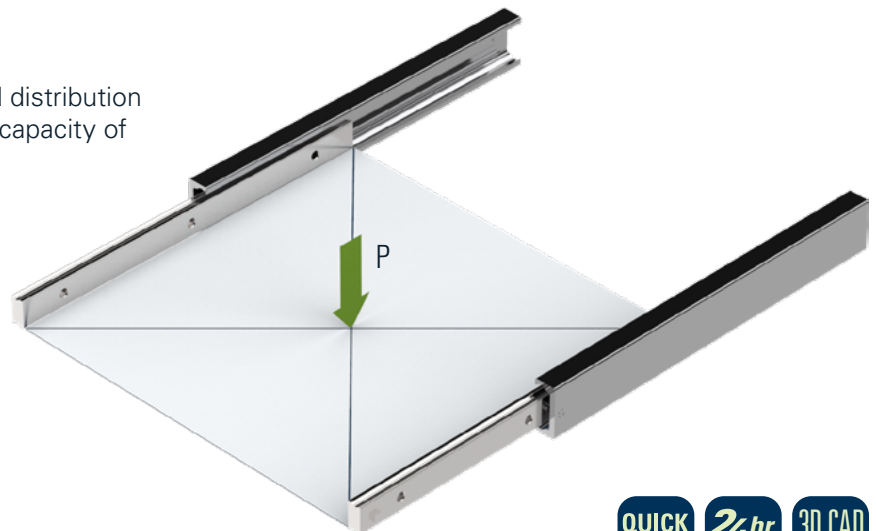
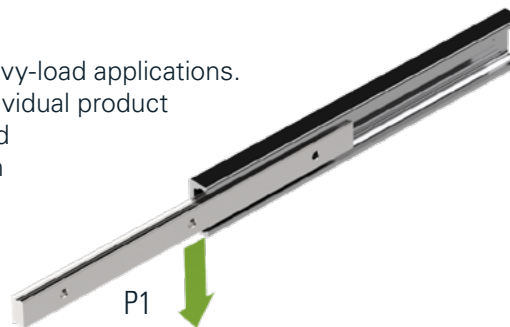

The life of a telescopic linear guide rail is determined by several factors, including effective load, directional shift frequency, running speed, precision of installation, vibration/shock, operational conditions, temperature, and lubrication.

Equivalent Load (LF)

$$LF = F_y + \left(\frac{F_z}{C_{0-ax}} + \frac{M_x}{M_{x-max}} + \frac{M_y}{M_{y-max}} + \frac{M_z}{M_{z-max}} \right) \times C_{0-rad}$$

- F_y : Actual load in Y direction (N)
- F_z : Actual load in Z direction (N)
- M_x : Actual moment load in X direction (N·m)
- M_y : Actual moment load in Y direction (N·m)
- M_z : Actual moment load in Z direction (N·m)

(The following can be taken from the Load Capacity table)

- C_{0-rad} : Load capacity in Y direction (N)
- C_{0-ax} : Load capacity in Z direction (N)
- M_{x-max} : Moment capacity in X direction (N·m)
- M_{y-max} : Moment capacity in Y direction (N·m)
- M_{z-max} : Moment capacity in Z direction (N·m)

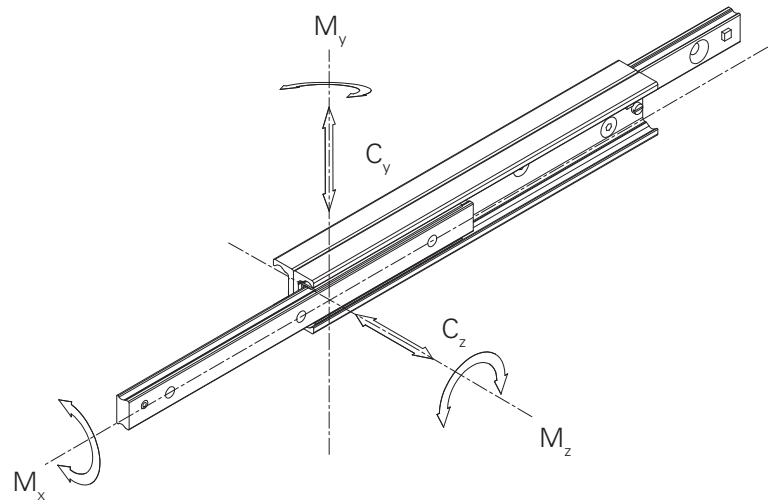

Life in Kilometers (L_{km})

$$L_{km} = 100 \times \left(\frac{C_{100}}{LF \times f} \right)$$

- C_{100} : Load capacity factor.
- f : Application Coefficient

Please check the detailed load parameters for each product located on page 7-8 for partial extension rails, and page 9-10 for full extension rails.

Application Characteristics	f value
<ul style="list-style-type: none"> • No vibration/shock • Low speed • Low directional change frequency • Clean operational environment 	1.3 - 1.8
<ul style="list-style-type: none"> • Light vibration/shock • Medium speed • Medium directional change frequency • Medium exposure to dirt 	1.8 - 2.3
<ul style="list-style-type: none"> • Heavy vibration/shock • High speed • High directional change frequency • High exposure to dirt 	2.3 - 3.5

Partial Extension Rails

Size 28

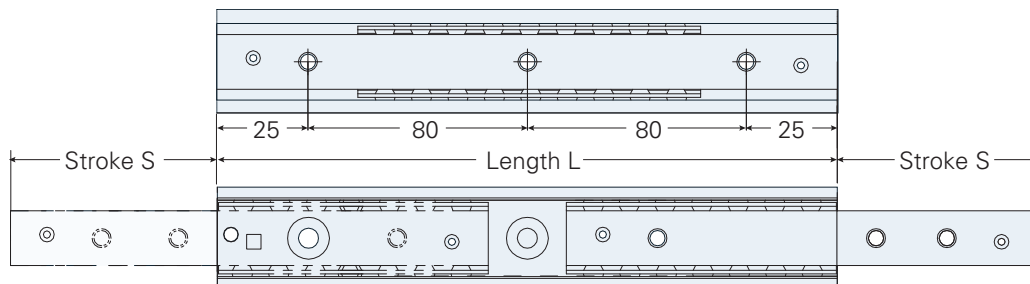
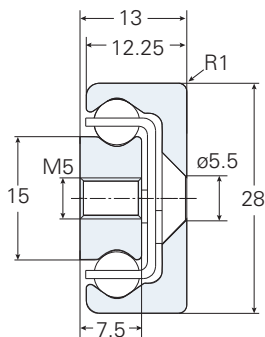

Product Specifications

Part #	L		S		C_y		C_z		M_x		M_y		M_z		C_{100}		# of holes
	in	mm	in	mm	lbf	N	lbf	N	ft/lb	N-m	ft/lb	N-m	ft/lb	N-m	lbf	N	
HTPE28-130	5.12	130	2.91	74	137.59	612	96.67	430	11.80	16	15.49	21	21.39	29	196.27	873	2
HTPE28-210	8.27	210	4.57	116	251.12	1,117	175.81	782	19.91	27	43.51	59	61.21	83	354.99	1,579	3
HTPE28-290	11.42	290	5.83	148	435.03	1,935	304.63	1,355	29.50	40	98.08	133	137.91	187	605.44	2,693	4
HTPE28-370	14.57	370	7.48	190	549.91	2,446	384.89	1,712	37.61	51	157.82	214	225.66	306	765.06	3,403	5
HTPE28-450	17.72	450	9.13	232	664.57	2,956	465.38	2,070	45.72	62	232.30	315	331.86	450	926.26	4,120	6
HTPE28-530	20.87	530	10.79	274	779.45	3,467	545.64	2,427	53.83	73	321.53	436	457.23	620	1,087.01	4,835	7
HTPE28-610	24.02	610	12.44	316	894.33	3,978	626.12	2,785	61.21	83	425.52	577	604.72	820	1,249.55	5,558	8
HTPE28-690	27.17	690	14.09	358	1,009.22	4,489	706.38	3,142	69.32	94	542.77	736	775.07	1,051	1,410.30	6,273	9
HTPE28-770	30.31	770	15.75	400	1,123.20	4,996	786.65	3,499	77.43	105	674.78	915	964.60	1,308	1,570.37	6,985	10
HTPE28-850	33.46	850	17.05	433	1,310.48	5,829	917.72	4,082	87.02	118	859.88	1,166	1,229.35	1,667	1,823.97	8,113	11
HTPE28-930	36.61	930	18.70	475	1,424.46	6,336	997.53	4,437	95.87	130	1,025.07	1,390	1,463.86	1,985	1,980.67	8,810	12
HTPE28-1010	39.76	1,010	20.35	517	1,539.79	6,849	1,078.01	4,795	103.24	140	1,204.28	1,633	1,717.55	2,329	2,141.64	9,526	13
HTPE28-1090	42.91	1,090	22.01	559	1,654.45	7,359	1,157.82	5,150	111.36	151	1,396.76	1,894	1,994.10	2,704	2,301.93	10,239	14
HTPE28-1170	46.06	1,170	23.66	601	1,768.88	7,868	1,238.31	5,508	119.47	162	1,604.72	2,176	2,292.77	3,109	2,462.46	10,953	15

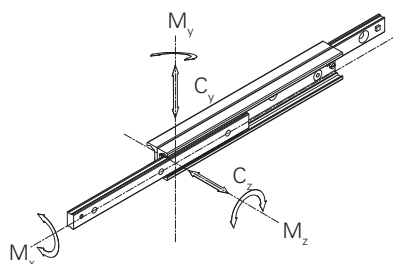

Partial Extension Rails

Size 43

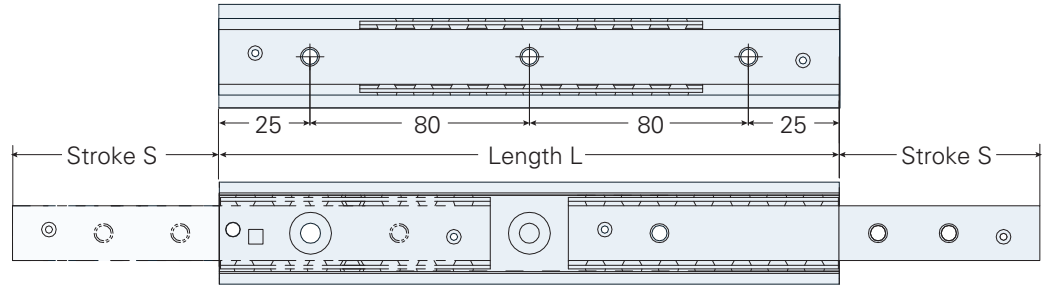
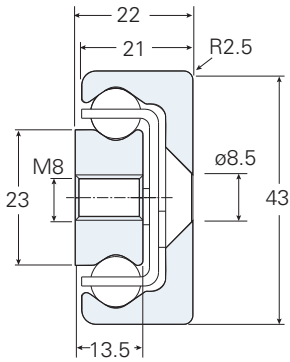

Product Specifications

Part #	L		S		C_y		C_z		M_x		M_y		M_z		C_{100}		# of holes
	in	mm	in	mm	lbf	N	lbf	N	ft/lb	N-m	ft/lb	N-m	ft/lb	N-m	lbf	N	
HTPE43-210	8.27	210	4.84	123	358.81	1,596	251.35	1,118	44.99	61	62.68	85	89.23	121	514.39	2,288	3
HTPE43-290	11.42	290	6.22	158	645.91	2,873	452.34	2,012	69.32	94	148.97	202	213.13	289	911.65	4,055	4
HTPE43-370	14.57	370	8.19	208	759.44	3,378	531.70	2,365	85.55	116	226.40	307	325.22	441	1,077.79	4,794	5
HTPE43-450	17.72	450	9.57	243	1,054.63	4,691	738.53	3,285	110.62	150	376.11	510	538.35	730	1,484.26	6,602	6
HTPE43-530	20.87	530	10.94	278	1,357.91	6,040	950.54	4,228	136.43	185	562.68	763	803.10	1,089	1,899.96	8,451	7
HTPE43-610	24.02	610	12.32	313	1,666.37	7,412	1,166.59	5,189	159.29	216	785.40	1,065	1,120.94	1,520	2,321.27	10,325	8
HTPE43-690	27.17	690	14.29	363	1,768.21	7,865	1,237.86	5,506	175.52	238	955.01	1,295	1,364.31	1,850	2,474.60	11,007	9
HTPE43-770	30.31	770	15.67	398	2,075.76	9,233	1,453.46	6,465	201.33	273	1,240.41	1,682	1,772.12	2,403	2,895.46	12,879	10
HTPE43-850	33.46	850	17.05	433	2,386.92	10,617	1,670.41	7,430	224.93	305	1,563.42	2,120	2,233.78	3,029	3,319.02	14,763	11
HTPE43-930	36.61	930	19.02	483	2,485.61	11,056	1,740.11	7,740	241.89	328	1,799.41	2,440	2,570.06	3,485	3,468.97	15,430	12
HTPE43-1010	39.76	1,010	20.39	518	2,795.64	12,435	1,957.06	8,705	265.49	360	2,184.37	2,962	3,120.21	4,231	3,891.86	17,311	13
HTPE43-1090	42.91	1,090	22.36	568	2,895.23	12,878	2,026.75	9,015	282.45	383	2,460.18	3,336	3,515.49	4,767	4,042.49	17,981	14
HTPE43-1170	46.06	1,170	23.74	603	3,205.04	14,256	2,243.71	9,980	306.78	416	2,909.29	3,945	4,155.60	5,635	4,465.15	19,861	15
HTPE43-1250	49.21	1,250	25.12	638	3,516.19	15,640	2,461.33	10,948	331.86	450	3,390.12	4,597	4,846.61	6,572	4,889.61	21,749	16
HTPE43-1330	52.36	1,330	27.09	688	3,614.21	16,076	2,530.35	11,255	347.35	471	3,735.99	5,066	5,337.76	7,238	5,038.67	22,412	17
HTPE43-1410	55.51	1,410	28.46	723	3,924.91	17,458	2,747.30	12,220	371.68	504	4,281.71	5,806	6,117.99	8,296	5,462.68	24,298	18
HTPE43-1490	58.66	1,490	29.84	758	4,237.41	18,848	2,965.83	13,192	396.76	538	4,866.52	6,599	6,951.33	9,426	5,887.37	26,187	19
HTPE43-1570	61.81	1,570	31.22	793	4,550.36	20,240	3,185.25	14,168	421.09	571	5,488.20	7,442	7,839.23	10,630	6,314.07	28,085	20
HTPE43-1650	64.96	1,650	33.19	843	4,645.46	20,663	3,252.02	14,465	437.32	593	5,922.57	8,031	8,460.91	11,473	6,460.21	28,735	21
HTPE43-1730	68.11	1,730	34.57	878	4,958.41	22,055	3,470.77	15,438	461.65	626	6,606.19	8,958	9,436.58	12,796	6,885.79	30,628	22
HTPE43-1810	71.26	1,810	36.54	928	5,053.96	22,480	3,538.22	15,738	477.88	648	7,082.60	9,604	10,116.52	13,718	7,032.37	31,280	23
HTPE43-1890	74.41	1,890	37.91	963	5,365.33	23,865	3,756.52	16,709	502.95	682	7,828.17	10,615	11,182.15	15,163	7,457.28	33,170	24
HTPE43-1970	77.56	1,970	39.88	1,013	5,447.39	24,230	3,824.19	17,010	519.91	705	8,344.40	11,315	11,918.88	16,162	7,604.99	33,827	25

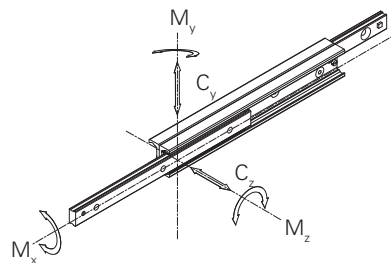

Full Extension Rails

Size 28

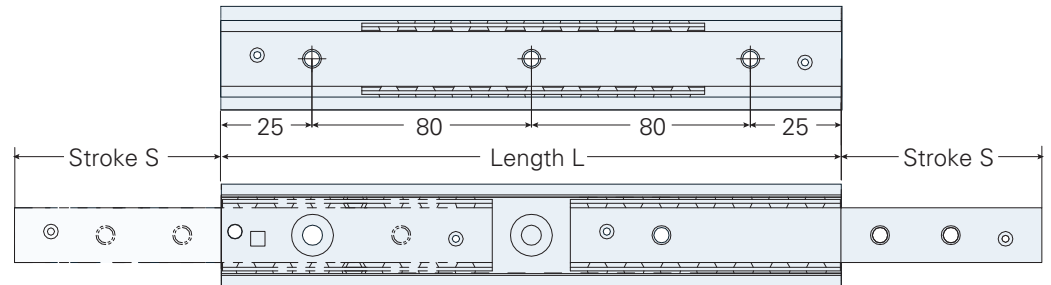
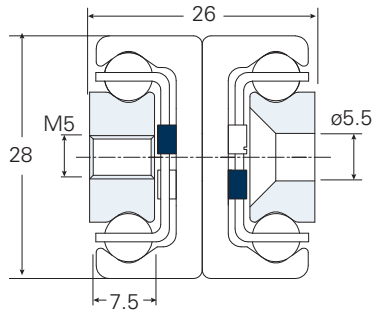

Product Specifications

Part #	L		S		C_y		C_z		C_{100}		# of holes
	in	mm	in	mm	lbf	N	lbf	N	lbf	N	
HTDB28-130	5.12	130	5.83	148	53.06	236	37.10	165	80.49	358	2
HTDB28-210	8.27	210	9.13	232	97.35	433	68.12	303	147.48	656	3
HTDB28-290	11.42	290	11.65	296	172.66	768	120.95	538	259.67	1,155	4
HTDB28-370	14.57	370	14.96	380	217.85	969	106.12	472	327.34	1,456	5
HTDB28-450	17.72	450	18.27	464	263.04	1,170	86.78	386	395.68	1,760	6
HTDB28-530	20.87	530	21.57	548	249.10	1,108	73.29	326	464.25	2,065	7
HTDB28-610	24.02	610	24.92	633	214.93	956	63.17	281	532.82	2,370	8
HTDB28-690	27.17	690	28.23	717	189.97	845	55.76	248	600.94	2,673	9
HTDB28-770	30.31	770	31.54	801	169.51	754	49.46	220	669.51	2,978	10
HTDB28-850	33.46	850	34.09	866	160.07	712	46.99	209	784.40	3,489	11
HTDB28-930	36.61	930	37.40	950	145.46	647	42.72	190	850.94	3,785	12
HTDB28-1010	39.76	1,010	40.71	1,034	133.32	593	39.34	175	918.62	4,086	13
HTDB28-1090	42.91	1,090	44.02	1,118	123.20	548	36.20	161	986.74	4,389	14
HTDB28-1170	46.06	1,170	47.32	1,202	114.43	509	33.72	150	1,054.63	4,691	15

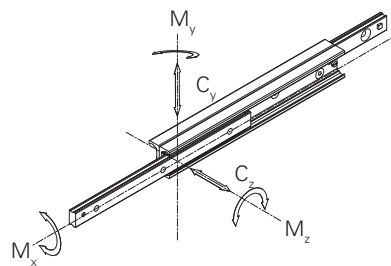

Full Extension Rails

Size 43

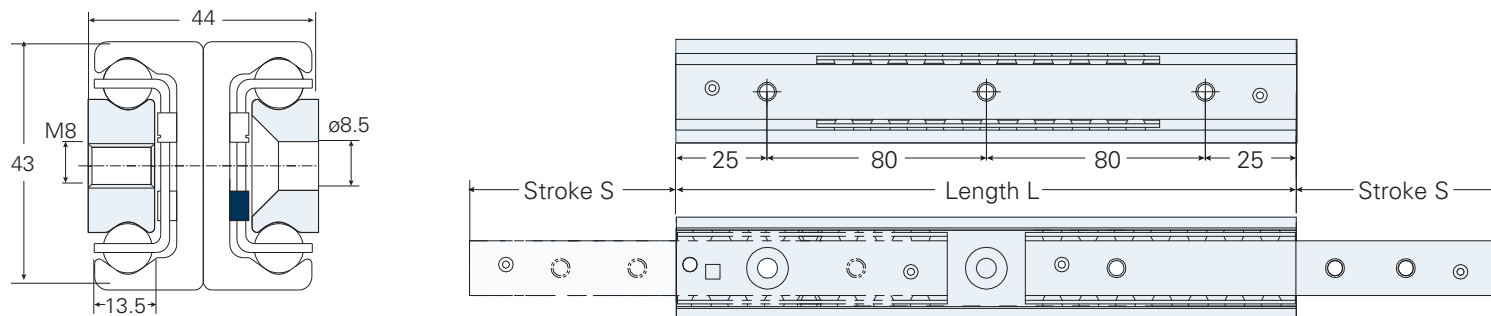

Product Specifications

Part #	L		S		C_y		C_z		C_{100}		# of holes
	in	mm	in	mm	lbf	N	lbf	N	lbf	N	
HTDB43-210	8.27	210	9.69	246	136.24	606	95.55	425	207.51	923	3
HTDB43-290	11.42	290	12.44	316	250.67	1,115	175.58	781	379.27	1,687	4
HTDB43-370	14.57	370	16.38	416	292.72	1,302	205.04	912	443.79	1,974	5
HTDB43-450	17.72	450	19.13	486	410.75	1,827	287.77	1,280	621.40	2,764	6
HTDB43-530	20.87	530	21.89	556	534.17	2,376	322.62	1,435	804.86	3,580	7
HTDB43-610	24.02	610	24.65	626	659.85	2,935	292.94	1,303	992.36	4,414	8
HTDB43-690	27.17	690	28.58	726	695.14	3,092	246.40	1,096	1,047.89	4,661	9
HTDB43-770	30.31	770	31.34	796	687.05	3,056	228.87	1,018	1,234.94	5,493	10
HTDB43-850	33.46	850	34.09	866	640.29	2,848	212.46	945	1,424.24	6,335	11
HTDB43-930	36.61	930	38.03	966	563.85	2,508	187.72	835	1,477.52	6,572	12
HTDB43-1010	39.76	1,010	40.79	1,036	531.70	2,365	177.16	788	1,666.14	7,411	13
HTDB43-1090	42.91	1,090	43.54	1,106	503.37	2,239	167.49	745	1,856.34	8,257	14
HTDB43-1170	46.06	1,170	47.48	1,206	454.14	2,020	151.30	673	1,908.50	8,489	15
HTDB43-1250	49.21	1,250	50.24	1,276	433.68	1,929	144.33	642	2,098.02	9,332	16
HTDB43-1330	52.36	1,330	54.17	1,376	397.26	1,767	132.19	588	2,151.08	9,568	17
HTDB43-1410	55.51	1,410	56.93	1,446	380.85	1,694	127.02	565	2,340.15	10,409	18
HTDB43-1490	58.66	1,490	59.69	1,516	366.01	1,628	121.85	542	2,530.35	11,255	19
HTDB43-1570	61.81	1,570	62.44	1,586	352.52	1,568	117.58	523	2,721.45	12,105	20
HTDB43-1650	64.96	1,650	66.38	1,686	328.24	1,460	109.49	487	2,772.03	12,330	21
HTDB43-1730	68.11	1,730	69.13	1,756	316.32	1,407	105.67	470	2,962.68	13,178	22
HTDB43-1810	71.26	1,810	73.07	1,856	297.21	1,322	98.92	440	3,013.94	13,406	23
HTDB43-1890	74.41	1,890	75.83	1,926	287.99	1,281	95.77	426	3,204.14	14,252	24
HTDB43-1970	77.56	1,970	79.76	2,026	271.36	1,207	90.38	402	3,256.07	14,483	25

